

FAGOR HANDWHEEL MODEL: PS-SF-141005

Manual version: 1503
Dimensions in mm

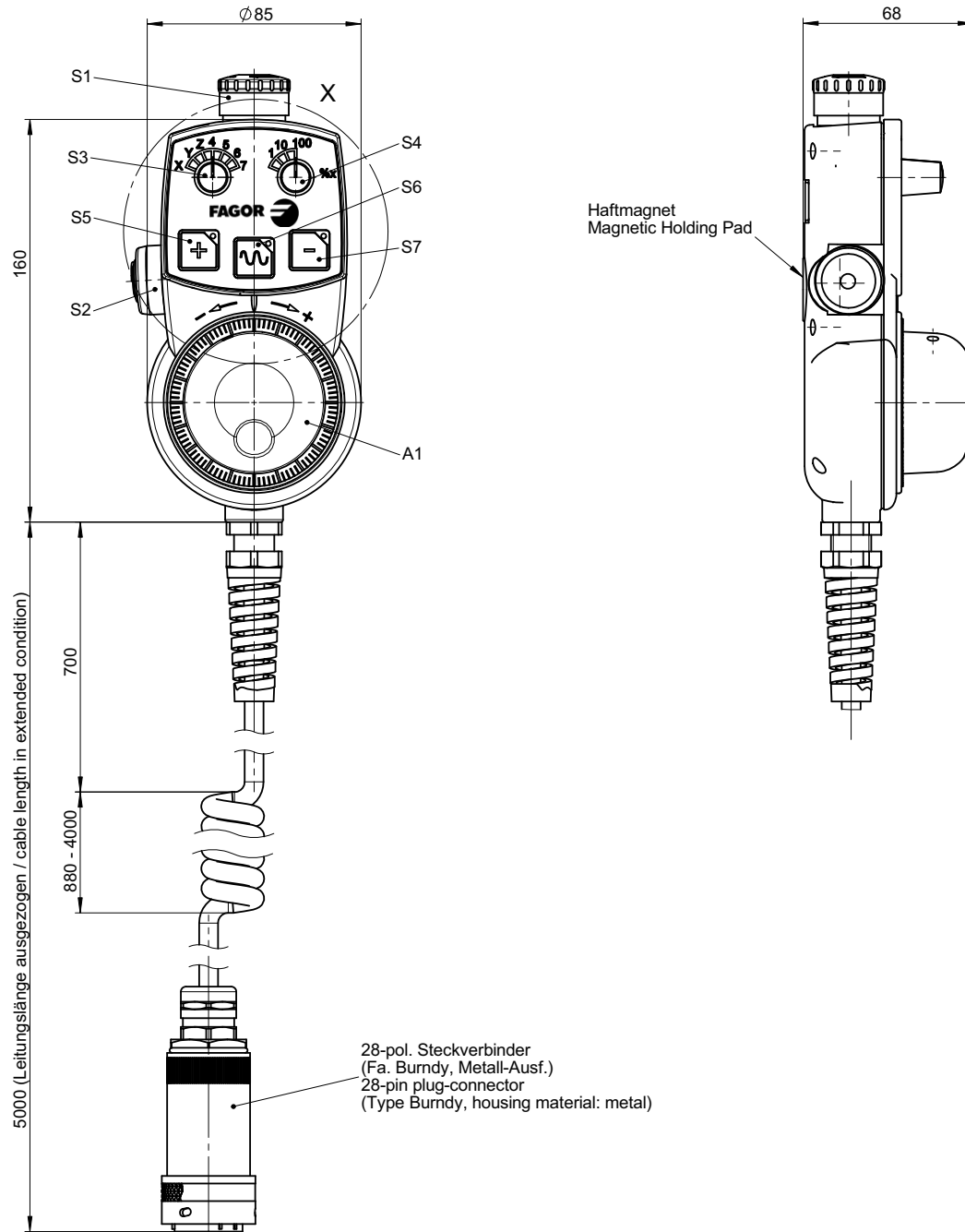

28-pol. Steckverbinder
(Fa. Burndy, Metall-Ausf.)
28-pin plug-connector
(Type Burndy, housing material: metal)

28-pol. Flanschdose (Metall-Ausf.) mit Buchsenkontakten beigelegt
28-pin flange-socket (housing material: metal) with socket contacts enclosed

Für Handradsignale geschirmte Leitung verwenden.
Use for handwheel signals shielded cable.
Schirm an Flanschdose anschliessen.
Connect shield to flange socket.

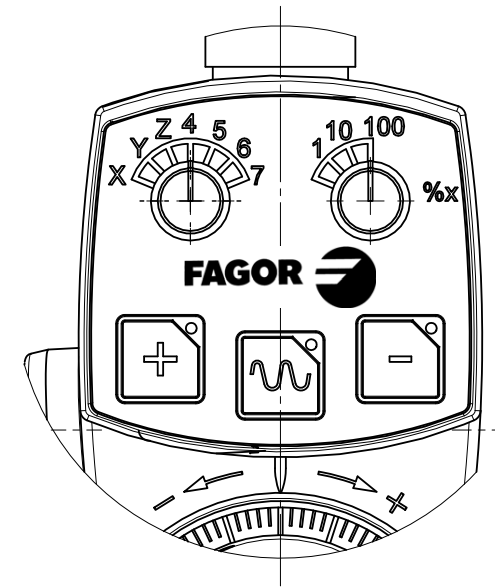

FAGOR HANDWHEEL MODEL: PS-SF-141005

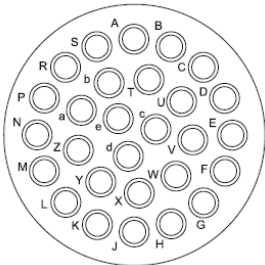
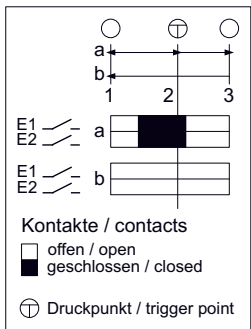
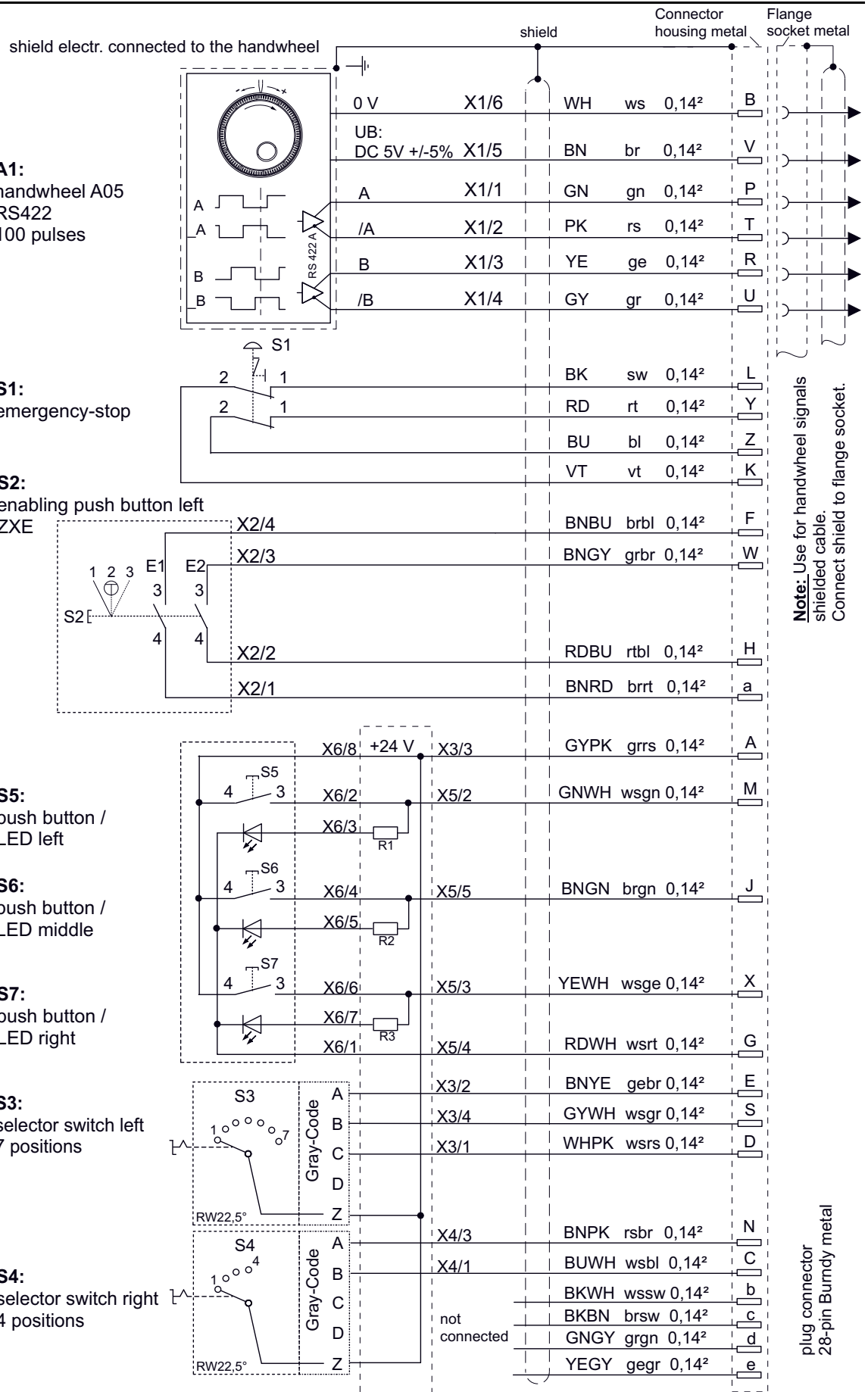

connector male pinout

S3	DCBA	
1	0000	X
2	0001	Y
3	0011	Z
4	0010	4
5	0110	5
6	0111	6
7	0101	7

S4	DCBA	
1	0000	
2	0001	1
3	0011	10
4	0010	100