

FAGOR AUTOMATION S.COOP.

Brushless AC
servo drives
~ **MCS series** ~

Ref.1501



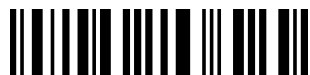

FAGOR 



14460062

Original instructions

Title	Brushless AC Servo Drives. MCS series
Type of documentation	Description, installation and startup of motors and digital drives.
Name	MAN REGUL MCS (IN)
Reference	Ref.1501
Software	version 02.0x
WinDDSSetup	version 08.0x
Electronic document	man_mcs.pdf
Headquarters	FAGOR AUTOMATION S. COOP. B.º San Andrés 19, Apdo. 144 20500 ARRASATE- MONDRAGÓN www.fagorautomation.com info@fagorautomation.es
	34-943-719200
	34-943-771118 (Technical Service Depart.)

The information described in this manual may be subject to changes due to technical modifications. FAGOR AUTOMATION, S. Coop. reserves the right to change the contents of this manual without prior notice.

The contents of this manual have been verified and matched with the product described here. Even so, it may contain involuntary errors that make it impossible to ensure an absolute match. However, the contents of this document are regularly checked and updated implementing the pertinent corrections in a later edition.

All rights reserved. No part of this documentation may be copied, transmitted, transcribed, stored in a backup device or translated into another language without Fagor Automation's permission.

DUAL-USE products.

Products manufactured by Fagor Automation S. Coop. included on the list of dual-use products according to regulation (UE) Nr 1382/2014. Their product identification includes the text -MDU and require an export license depending on destination.

WARRANTY

INITIAL WARRANTY

All products manufactured or marketed by FAGOR carry a 12-month warranty for the end user.

In order to prevent the possibility of having the time period from the time a product leaves our warehouse until the end user actually receives it run against this 12-month warranty, the OEM or distributor must communicate to FAGOR the destination, identification and installation date of the machine by filling out the Warranty Form that comes with each product.

The starting date of the warranty for the user will be the one appearing as the installation date of the machine on the warranty form.

This system ensures the 12-month warranty period for the user.

FAGOR offers a 12-month period for the OEM or distributor for selling and installing the product. This means that the warranty starting date may be up to one year after the product has left our warehouse so long as the warranty control sheet has been sent back to us. This translates into the extension of warranty period to two years since the product left our warehouse. If this sheet has not been sent to us, the warranty period ends 15 months from when the product left our warehouse.

FAGOR is committed to repairing or replacing its products from the time when the first such product was launched up to 8 years after such product has disappeared from the product catalog.

It is entirely up to FAGOR to determine whether a repair is to be considered under warranty.

EXCLUDING CLAUSES

The repair will take place at our facilities. Therefore, all shipping expenses as well as travelling expenses incurred by technical personnel are NOT under warranty even when the unit is under warranty.

The warranty will be applied so long as the equipment has been installed according to the instructions, it has not been mistreated or damaged by accident or negligence and has been handled by personnel authorized by FAGOR.

If once the service call or repair has been completed, the cause of the failure is not to be blamed on the FAGOR product, the customer must cover all generated expenses according to current fees.

No other implicit or explicit warranty is covered and FAGOR AUTOMATION shall not be held responsible, under any circumstances, of the damage which could be originated.

SERVICE CONTRACTS

Service and Maintenance Contracts are available for the customer within the warranty period as well as outside of it.

DECLARATION OF CONFORMITY

Manufacturer: Fagor Automation, S. Coop.
B.º San Andrés 19, C.P. 20500, Mondragón - Gipuzkoa - (SPAIN)

We hereby declare, under our responsibility that the product:

Fagor AC Brushless Servo Drive System

consisting of the following drives modules:

MCS- 05L, MCS-10L, MCS-20L, MCS- 30L, MCS- 04H, MCS- 08H, MCS-16H

and axis feed servo motors:

FXM1, FXM3, FXM5, FXM7, FKM2, FKM4, FKM6

Note. Some additional characters may follow the model references indicated above. They all comply with the directives listed here. However, compliance may be verified on the label of the unit itself.

mentioned on this declaration, meet the requirements on:

Safety

EN 60204 -1: Machinery safety. Electrical equipment of the machines.
2006 Part 1: General requirements.

Electromagnetic Compatibility

EN 61800-3: EMC directive on servo drive systems.
2004

In compliance with EC Directives 2006/95/EC on Low Voltage and 2004/108/EC on Electrical Compatibility.

Fagor Automation, S. Coop.

Director Gerente
Pedro Ruiz de Aguirre

In Mondragón July 1st, 2009.

INTRODUCTION

FAGOR offers you a wide range of servo drive systems (AC Brushless motor and Digital Drive) for applications requiring between 1.2 and 33.6 Nm at speeds between 1200 rev/min and 4000 rev/min for FXM motors and between 1.7 and 23.5 Nm at speeds between 2000 rev/min and 6000 rev/min for FKM motors.

This manual describes the elements in detail and guides step by step through the installation and setup of the drive system.

When installed for the first time, it is a good idea to read the whole document.

Should you have any doubts or questions, please do not hesitate to contact our technicians at any of our subsidiaries worldwide.

Thank you for choosing FAGOR.

General index

BRUSHLESS AC MOTORS, FXM	7
Introduction	7
General characteristics	7
Dimensions	11
Power connectors and encoder output	13
Brake characteristics	15
Sales reference	16
BRUSHLESS AC MOTORS , FKM	17
Introduction	17
General characteristics	17
Dimensions	20
Power connectors and encoder output	21
Brake characteristics	23
Sales reference	24
A. C. SERVODRIVE	25
Introduction	25
General characteristics	25
Dimensions	26
Technical data	26
Connectors	27
Programming module	29
Front panel and pinout of the connectors	31
Characteristics plate	34
Sales reference	34
INSTALLATION	35
General considerations	35
Electrical connections	36
Cabling	40
Analog command signal connection	43
MCS-PC connection. RS-232 serial line	43
Diagram of the electrical cabinet	44
Initialization and adjustment	45
PARAMETERS, VARIABLES & COMMANDS	50
Notation	50
Groups	52
ERROR MESSAGES	80
PARAMETERS, VARIABLES & COMMANDS. IDs.....	87

This page intentionally left blank

BRUSHLESS AC MOTORS, FXM

Introduction

FXM series synchronous servo motors are AC Brushless, with permanent magnets.

They are ideal for any application requiring great positioning accuracy. They have a uniform output torque, high reliability and low maintenance.

They are designed to meet the IP 64 protection standard and, therefore, they are immune to liquid and dirt.

IP 64 means that it is protected against dust and against water jets. They incorporate a temperature sensor for monitoring the internal temperature. They also carry an optional electromechanical brake. The F class isolation on the motor maintains the dielectric properties as long as the work temperature stays below 150 °C (302 °F).

FXM1 FXM3 FXM5 FXM7

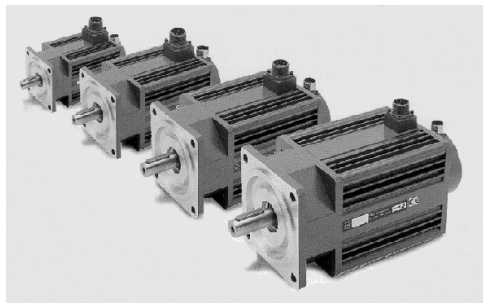

General characteristics

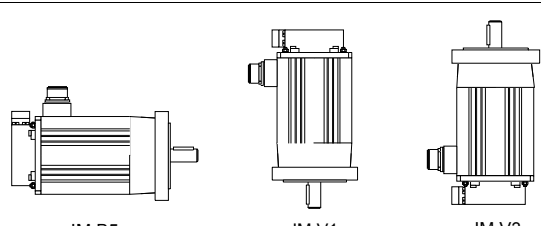
Excitation	Permanent rare earth magnets (SmCo)
Temperature sensor	Thermistor
Shaft end	Cylindrical with keyway (optional with no keyway)
Mounting	Face flange
Mounting method	IM B5 - IM V1 - IM V3 (as recommended by IEC-34-3-72)
Mechanical tolerances	Normal class (meets IEC-72/1971)
Balancing	Class N (R optional) (DIN 45665) whole-key balancing
Roller bearings' life	20000 hours
Noise	DIN 45635
Vibration resistance	Withstands 1g, along the shaft and 3g sideways ($g=9.81 \text{ m/s}^2$)
Electrical insulation	Class F (150 °C - 302 °F)
Insulation resistance	500 V DC, 10 M Ω or greater
Dielectric rigidity	1500 V AC, one minute
Protection degree	General: Standard IP 64. Shaft: Standard IP 64, IP 65 with oil seal
Storage temperature	From - 20 °C to + 80 °C (- 4 °F to + 176 °F)
Ambient temperature	From - 0 °C to + 40 °C (+ 32 °F to + 104 °F)
Working ambient humidity	From 20 % to 80 % (non condensing)
Brake	Optional in all models. See the section "brake characteristics"
Feedback	Incremental I/O TTL encoder SinCos or SinCoder sinusoidal encoder
Meaning of the codes of the mounting method.	 <p style="text-align: center;">IM B5 IM V1 IM V3</p>

Technical data of non-ventilated synchronous FXM motors with "F" winding (220 V AC).

Non-ventilated motors	Stall torque		Rated speed	Stall current	Peak current	Calculation power	Torque constant	Acceleration time	Inductance per phase	Resistance per phase	Inertia ¹	Mass ²	Drive peak torque				
	Mo	Mp											nN	Io	Imax	Pcal	kt
	Nm	Nm	rev/min	Arms	Arms	kW	Nm/Arms	ms	mH	Ω	kg·cm ²	kg	Nm	Nm	Nm	Nm	Nm
FXM11.40F.□□.□□□□	1.2	6	4000	2.0	10.0	0.5	0.6	8.4	12.0	4.60	1.2	3.3	3.0				
FXM12.40F.□□.□□□□	2.3	11	4000	3.9	18.7	1.0	0.6	7.2	5.5	1.45	1.9	4.3					
FXM13.40F.□□.□□□□	3.3	16	4000	5.6	27.2	1.4	0.6	6.8	3.5	0.80	2.6	6.4				11.0	
FXM14.20F.□□.□□□□	4.1	20	2000	3.5	17.1	0.9	1.2	3.5	10.0	2.30	3.3	7.6			12.0		16.0
FXM14.40F.□□.□□□□	4.1	20	4000	6.9	33.7	1.7	0.6	6.9	2.6	0.55	3.3	7.6				12.0	18.0
FXM31.20F.□□.□□□□	2.6	13	2000	2.2	11.0	0.5	1.2	5.6	24.0	5.05	3.5	5.5	6.0		12.0		
FXM31.40F.□□.□□□□	2.6	13	4000	4.4	22.0	1.1	0.6	11.3	6.1	1.25	3.5	5.5			6.0		13.0
FXM32.20F.□□.□□□□	5.1	25	2000	4.3	21.1	1.1	1.2	5.0	11.0	1.65	6.0	7.5			12.0		25.0
FXM32.40F.□□.□□□□	5.1	25	4000	8.4	41.2	2.1	0.6	10.0	2.9	0.44	6.0	7.5				12.0	18.0
FXM33.20F.□□.□□□□	7.3	36	2000	6.3	31.1	1.5	1.2	4.9	6.7	0.90	8.5	9.6				24.0	36.0
FXM33.40F.□□.□□□□	7.3	36	4000	12.0	59.2	3.1	0.6	9.9	1.8	0.25	8.5	9.6					18.0
FXM34.20F.□□.□□□□	9.3	46	2000	7.6	37.6	1.9	1.2	5.0	5.3	0.65	11.0	11.5					36.0
FXM34.40F.□□.□□□□	9.3	46	4000	15.0	74.2	3.9	0.6	10.0	1.3	0.17	11.0	11.5					18.0
FXM53.20F.□□.□□□□	11.9	59	2000	9.9	49.1	2.5	1.2	7.8	5.0	0.45	22.0	15.8				24.0	36.0
FXM53.30F.□□.□□□□	11.9	59	3000	14.8	73.0	3.7	0.8	11.7	2.2	0.20	22.0	15.8					24.0
FXM54.20F.□□.□□□□	14.8	74	2000	12.7	63.5	3.1	1.2	8.2	3.4	0.27	29.0	17.8					36.0
FXM55.12F.□□.□□□□	17.3	86	1200	9.1	45.2	2.2	1.9	5.3	7.2	0.55	36.0	20.0				38.0	57.0
FXM55.20F.□□.□□□□	17.3	86	2000	15.0	74.6	3.6	1.1	8.8	2.5	0.19	36.0	20.0					33.6
FXM73.12F.□□.□□□□	20.8	104	1200	10.7	53.5	2.6	1.9	7.4	9.8	0.60	61.0	29.0					57.0
FXM74.12F.□□.□□□□	27.3	135	1200	13.5	66.8	3.4	2.0	7.3	7.8	0.45	79.0	31.6					60.0
FXM75.12F.□□.□□□□	29.5	165	1200	15.0	83.9	3.7	2.0	7.4	5.9	0.31	97.0	36.0					60.0

1. When adding the mechanical brake to the motor (optional) also take into account the inertia values given in the table of section "brake characteristics".

2. When adding the mechanical brake to the motor (optional) also take into account its mass values given in the table of section "brake characteristics".

Note. In the combinations shown in bold letters, the drive will limit its peak current automatically so as not to damage the motor.

Technical data of non-ventilated synchronous FXM motors with “A” winding (400 V AC).

Non-ventilated motors	Stall torque	Stall peak torque	Rated speed	Stall current	Peak current	Calculation power	Torque constant	Acceleration time	Inductance per phase	Resistance per phase	Inertia ¹	Mass ²	Drive peak torque		
	Mo Nm	Mp Nm	nN rev/min	Io Arms	I _{max} Arms	P _{cal} kW	kt Nm/Arms	t _{ac} ms	L mH	R Ω	J kg·cm ²	M kg	MCS-04H Nm	MCS-08H Nm	MCS-16H Nm
FXM33.20A.□□.□□□□	7.3	36	2000	2.7	13.4	1.5	2.7	4.9	36	5.05	8.5	9.6	21.6		36.0
FXM33.30A.□□.□□□□	7.3	36	3000	4.1	20.0	2.3	1.8	7.4	16	2.20	8.5	9.6	14.2		28.5
FXM33.40A.□□.□□□□	7.3	36	4000	5.5	27.0	3.1	1.3	9.9	8.6	1.15	8.5	9.6			21.3
FXM34.20A.□□.□□□□	9.3	46	2000	3.4	17.0	1.9	2.7	5.0	26	3.45	11.0	11.5	21.9		43.8
FXM34.30A.□□.□□□□	9.3	46	3000	5.1	25.0	2.9	1.8	7.5	12	1.60	11.0	11.5			29.1
FXM34.40A.□□.□□□□	9.3	46	4000	6.9	34.0	3.9	1.4	10.0	6.6	0.85	11.0	11.5			21.6
FXM53.12A.□□.□□□□	11.9	59	1200	2.8	14.0	1.5	4.2	4.7	61	5.85	22.0	15.8	34.0		59.0
FXM53.20A.□□.□□□□	11.9	59	2000	4.7	23.0	2.5	2.5	7.8	22	2.15	22.0	15.8			40.5
FXM53.30A.□□.□□□□	11.9	59	3000	7.1	35.0	3.7	1.7	11.7	9.6	0.91	22.0	15.8			26.9
FXM54.12A.□□.□□□□	14.8	74	1200	3.5	17.6	1.9	4.2	4.9	44	3.70	29.0	17.8	33.8		67.7
FXM54.20A.□□.□□□□	14.8	74	2000	5.9	30.0	3.1	2.5	8.2	16	1.35	29.0	17.8			40.2
FXM54.30A.□□.□□□□	14.8	74	3000	8.7	44.0	4.7	1.7	12.3	7.3	0.64	29.0	17.8			27.2
FXM55.12A.□□.□□□□	17.3	86	1200	4.1	20.0	2.2	4.2	5.3	36	2.95	36.0	20.0	33.8		67.5
FXM55.20A.□□.□□□□	17.3	86	2000	6.7	33.0	3.6	2.6	8.8	13	1.05	36.0	20.0			41.3
FXM73.12A.□□.□□□□	20.8	104	1200	4.9	25.0	2.6	4.2	7.4	46	3.05	61.0	29.0			67.8
FXM73.20A.□□.□□□□	20.8	104	2000	8.2	41.0	4.4	2.5	12.3	17	1.10	61.0	29.0			40.6
FXM74.12A.□□.□□□□	27.3	135	1200	6.6	32.0	3.4	4.2	7.4	33	1.90	79.0	31.6			66.2
FXM75.12A.□□.□□□□	33.6	165	1200	8.0	39.0	4.2	4.2	7.4	27	1.45	97.0	36.0			67.2

1. When adding the mechanical brake to the motor (optional) also take into account the inertia values given in the table of section “brake characteristics”.
 2. When adding the mechanical brake to the motor (optional) also take into account its mass values given in the table of section “brake characteristics”.
- Note.** In the combinations shown in bold letters, the drive will limit its peak current automatically so as not to damage the motor.

Dimensions

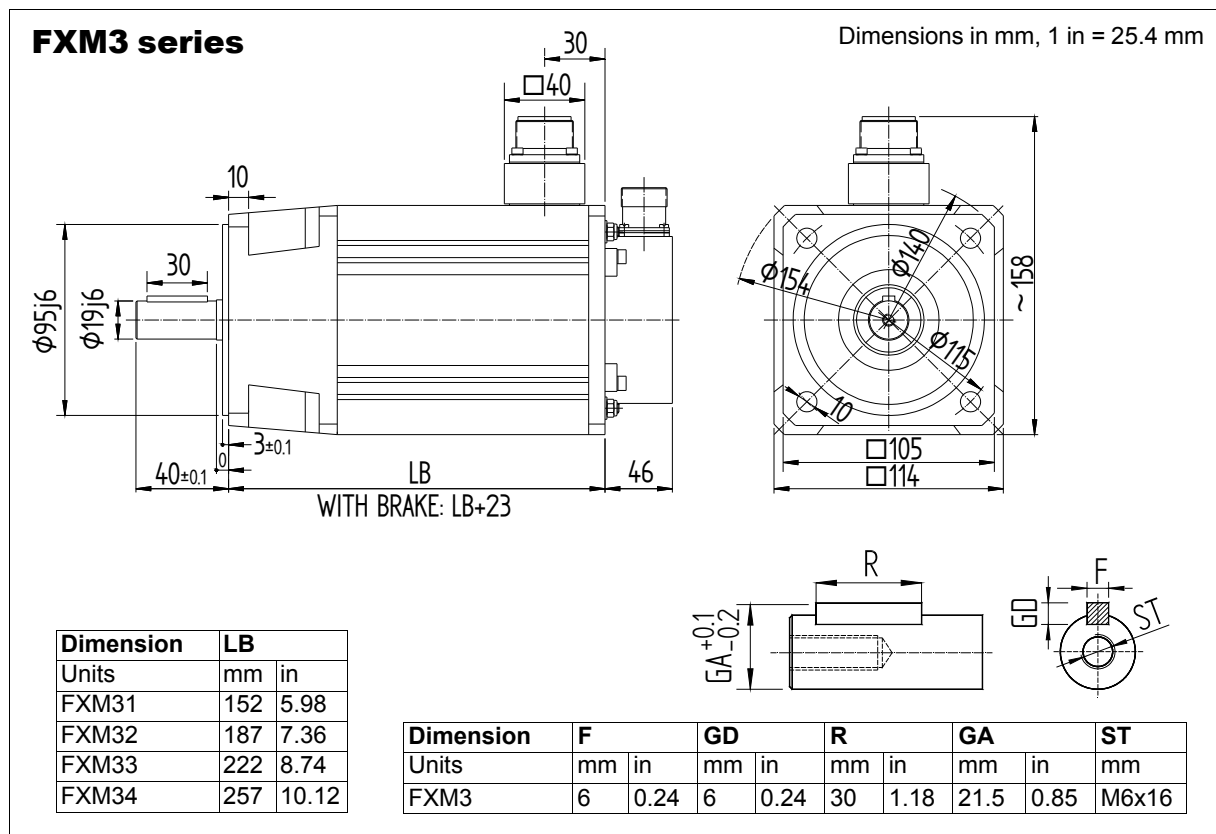
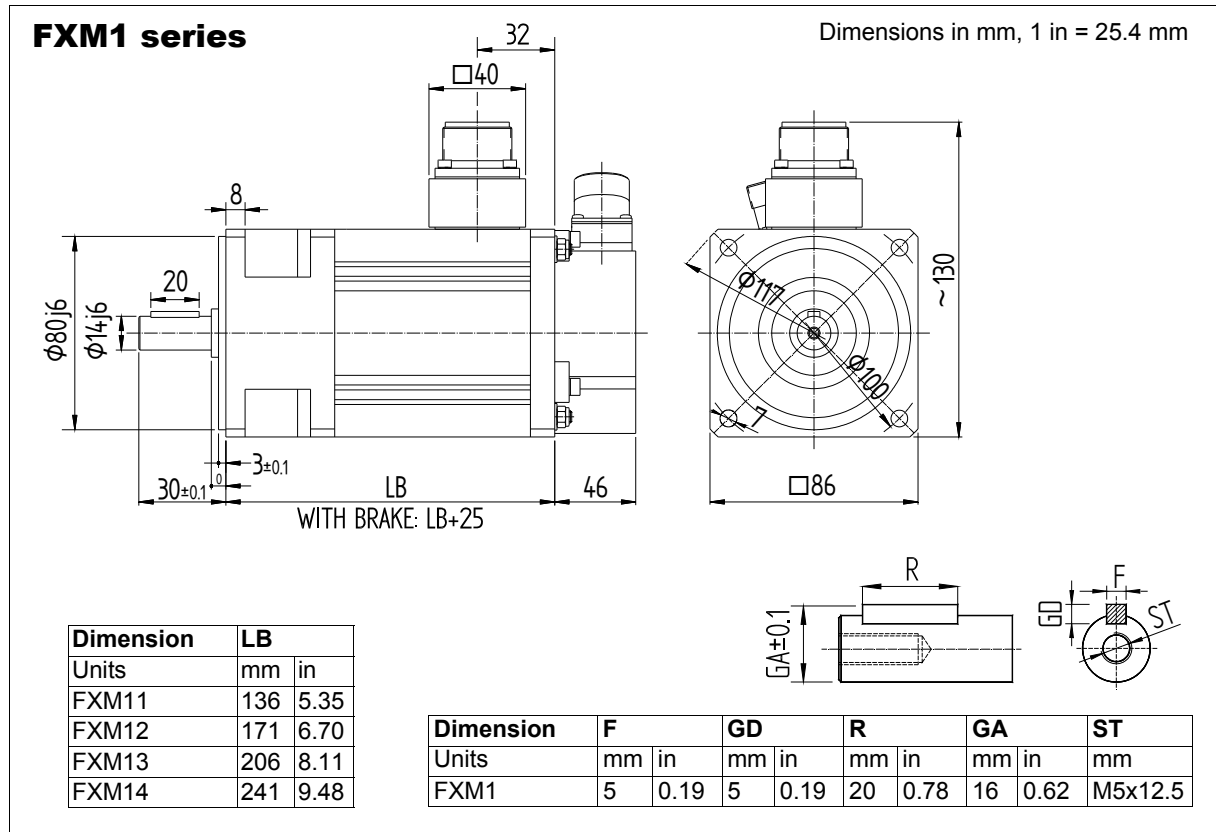

Power connectors and encoder output

The power connector includes the brake terminals (E, F). A voltage between 22 and 26 V DC releases the shaft. When installing the motor, verify that the brake releases the shaft completely before turning it for the first time. Connecting the motor windings in the order indicated on the connector (U, V, W), the shaft will turn clockwise (CWR, ClockWise Rotation).

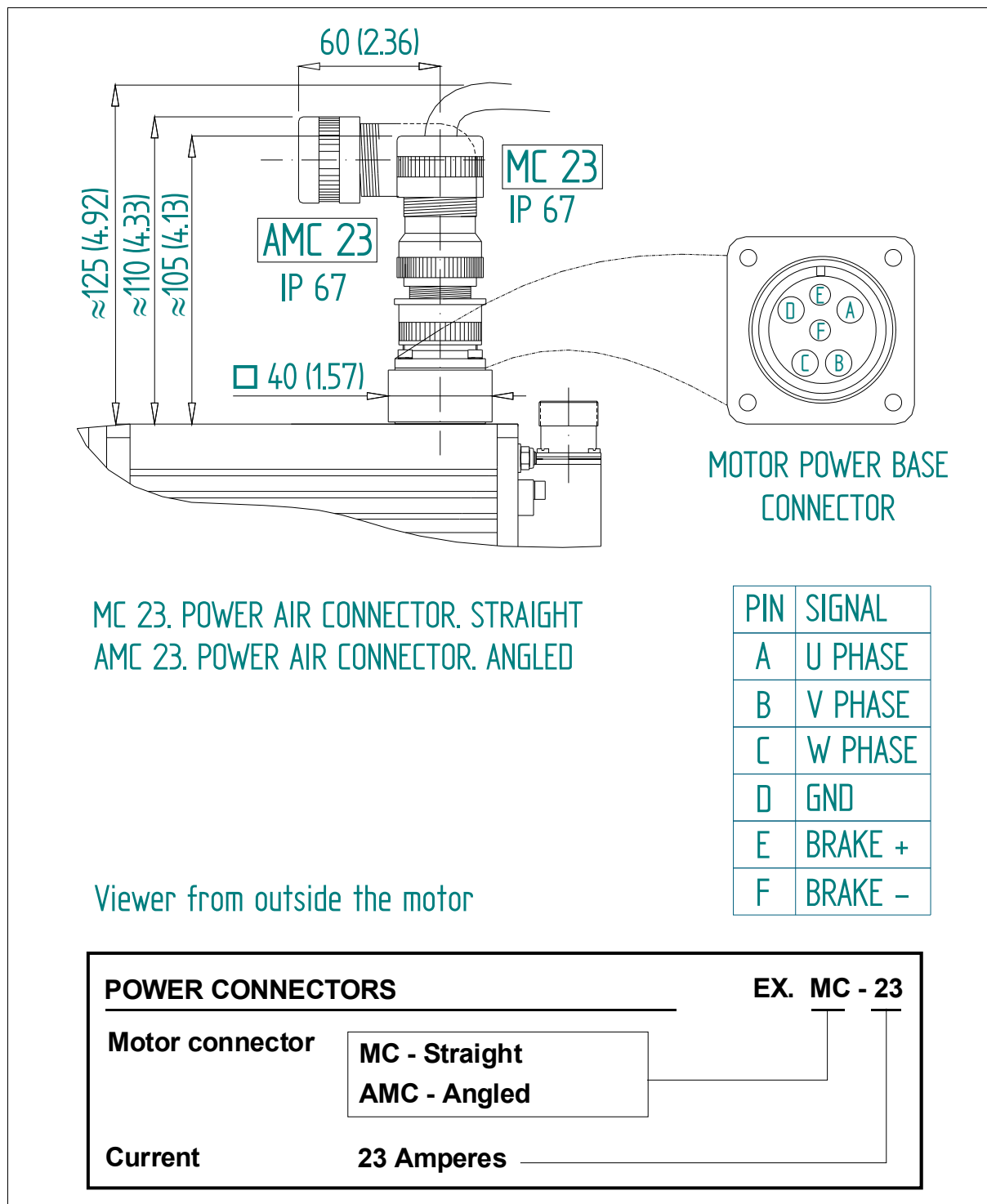

Pins of 9 and 10 of the connector of the incremental TTL encoder correspond to the thermistor used to monitor motor overheating.

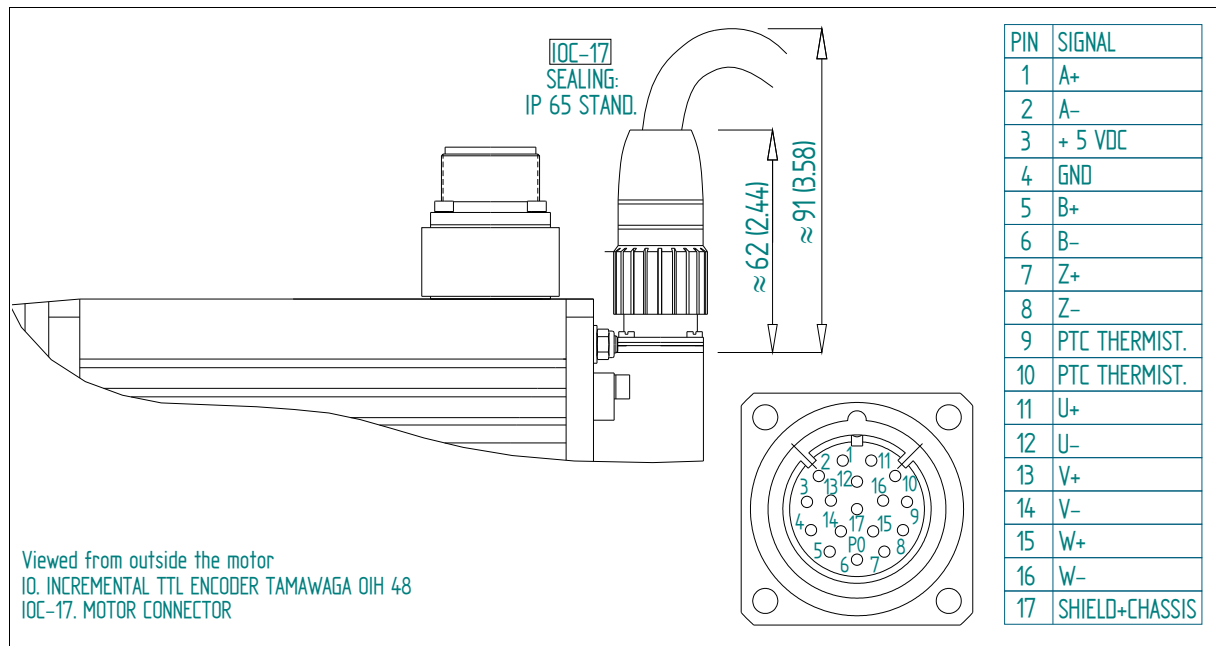

Pins of 3 and 4 of the SinCos or SinCoder encoder connector correspond to the thermistor used to monitor motor overheating.

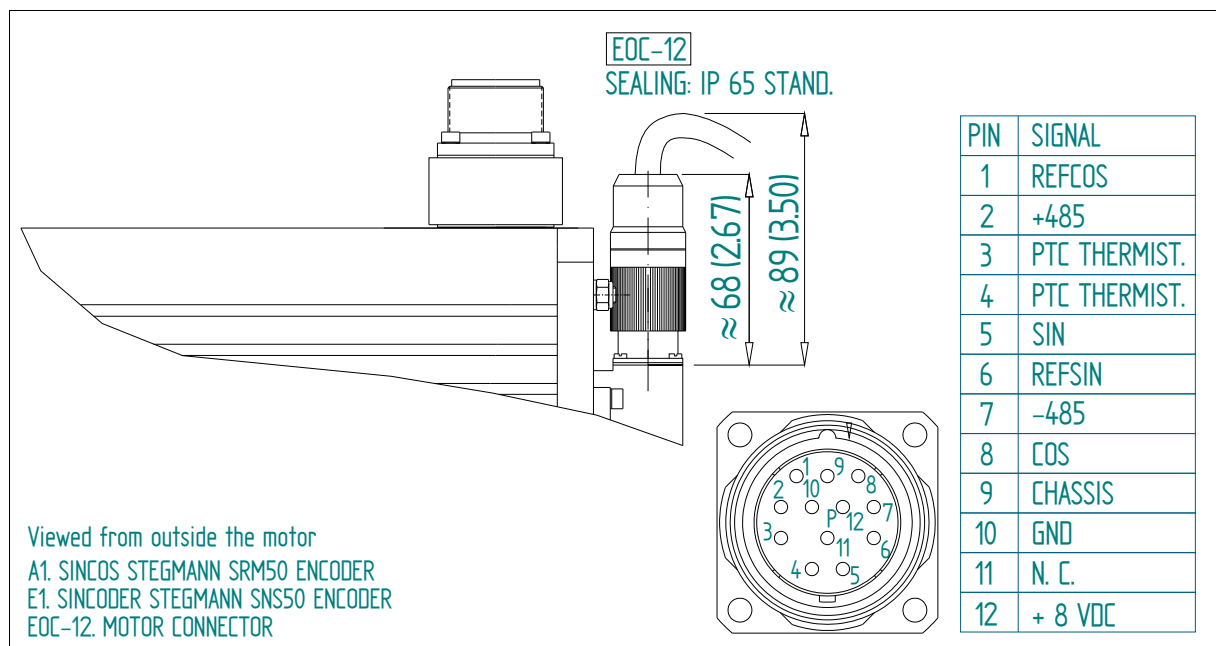

Brake characteristics

FXM motors have an optional brake that applies friction to the shaft. Its purpose is to immobilize or lock vertical axes, not to brake a moving axis.

Its main characteristics depending on the type of brake are:

Motor	Holding torque	Power consumption	On/Off time	Releasing voltage margin	Inertia	Mass
Units	N·m (in·lbf)	W (HP)	ms	V DC	kg·cm ²	kg (lbf)
FXM1	Mo motor	12 (0.016)	19/29	22-26	0.38	0.3 (0.66)
FXM3	Mo motor	16 (0.021)	20/29	22-26	1.06	0.6 (1.32)
FXM5	Mo motor	18 (0.024)	25/50	22-26	3.60	1.1 (2.42)
FXM7	Mo motor	35 (0.047)	53/97	22-26	31.80	4.1 (9.03)

Note. The maximum speed is 10000 rev/min, for all of them except for the brake that may be used on the FXM7 series that is 8000 rev/min.



WARNING.

NEVER use this brake to stop a moving axis!



WARNING.

- The brake must never exceed its maximum turning speed.
 - A voltage between 22 and 26 V DC releases the shaft. Make sure that no voltage over 26 V DC is applied that prevents the shaft from turning.
 - When installing the motor, make sure that the brake fully releases the shaft before making it turn for the first time.
-

Sales reference

		FXM □□.□□□.□□.□□□ - X □□									
FAGOR SYNCHRONOUS MOTOR											
SIZE	1, 3, 5, 7										
LENGTH	1, 2, 3, 4, 5										
RATED SPEED	12 1200 rev/min 30 3000 rev/min	20 2000 rev/min 40 4000 rev/min									
WINDING	F 220 V AC A 400 V AC										
FEEDBACK TYPE	I0 Incremental encoder (2500 ppt) A1 Absolute multi-turn SinCoder encoder (1024 ppt) E1 SinCoder encoder (1024 ppt)										
FLANGE & SHAFT	0 IEC Standard 1 Keyless shaft 8 NEMA standard (USA) 9 Special										
BRAKE OPTION	0 Without brake 1 With standard brake (24 V DC)										
FAN	0 Without fan 1 With Standard fan 9 With special fan										
SPECIAL CONFIGURATION	X										
SPECIFICATION	01 → ZZ Only when it has a special configuration (X) !										

NOTE. Motors with “F” winding may have an incremental I0 encoder. The rest of the feedback devices will only be available on motors with “A” winding.

BRUSHLESS AC MOTORS , FKM

Introduction

FKM synchronous servo motors are AC brushless with permanent magnets.

They are ideal for any application requiring great positioning accuracy. They have a uniform output torque, high reliability and low maintenance.

They are designed to meet the IP 64 protection standard and, therefore, they are immune to liquid and dirt.

IP 64 means that is protected against dust and against water jets. They have a KTY84-130 sensor to monitor the internal temperature. They also carry an optional electromechanical brake. They have rotating power and feedback connectors. The F class isolation on the motor maintains the dielectric properties as long as the work temperature stays below 150 °C (302 °F).

FKM2 FKM4 FKM6



General characteristics

Excitation	Permanent rare earth magnets (Nd-Fe-B)
Temperature sensor	Thermistor PTC KTY84-130
Shaft end	Cylindrical keyless (optional with keyway)
Mounting	Face flange with through holes
Mounting method	IM B5 - IM V1 - IM V3 (as recommended by IEC-34-3-72)
Mechanical tolerances	Normal class (meets IEC-72/1971)
Balancing	Class N (R optional) (DIN 45665) half-key balancing
Roller bearings' life	20000 hours
Noise	DIN 45635
Vibration resistance	Withstands 1g along the shaft and 3g sideways ($g=9.81m/s^2$)
Electrical insulation	Class F (150 °C - 302 °F)
Insulation resistance	500 V DC, 10 MΩ or greater
Dielectric rigidity	1500 V AC, one minute
Protection degree	General: Standard IP 64. Shaft: Standard IP 64, IP 65 with oil seal
Storage temperature	From - 20 °C to + 80 °C (- 4 °F to + 176 °F)
Ambient temperature	From - 0 °C to + 40 °C (+ 32 °F to + 104 °F)
Working ambient	From 20 % to 80 % (non condensing)
Brake	Optional in all models. See the section "brake characteristics"
Feedback	Incremental I0 TTL encoder SinCos or SinCoder encoder
Meaning of the codes of the mounting method	<p style="text-align: center;">IM B5 IM V1 IM V3</p>

Technical data of non-ventilated synchronous FKM motors with “A” winding (400 V AC).

Non-ventilated motors	Stall torque	Stall peak torque	Rated speed	Stall current	Peak current	Calculation power	Torque constant	Acceleration time	Inductance per phase	Resistance per phase	Inertia ¹	Mass ²	Drive peak torque	
	Mo Nm	Mp Nm	nN rev/min	Io Arms	Imax Arms	Pcal kW	kt Nm/Arms	tac ms	L mH	R Ω	J kg·cm ²	M kg	MCS-08H Nm	MCS-16H Nm
FKM21.60A.□□.□□□□	1.7	7	6000	2.8	11	1.1	0.60	14.4	7.70	2.600	1.6	4.2	4.8	7.0
FKM22.30A.□□.□□□□	3.2	13	3000	2.4	10	1.0	1.33	7.0	16.00	3.950	2.9	5.3	10.4	13.0
FKM22.50A.□□.□□□□	3.2	13	5000	4.0	16	1.7	0.80	11.7	5.80	1.400	2.9	5.3	6.4	12.8
FKM22.60A.□□.□□□□	3.2	13	6000	4.5	18	2.0	0.71	14.0	4.60	1.100	2.9	5.3	-	11.3
FKM42.30A.□□.□□□□	6.3	25	3000	4.6	19	2.0	1.36	10.7	8.60	1.450	8.5	7.8	-	21.7
FKM42.45A.□□.□□□□	6.3	25	4500	6.9	28	3.0	0.91	16.0	3.90	0.675	8.5	7.8	-	14.5
FKM42.60A.□□.□□□□	6.3	25	6000	8.5	34	3.9	0.74	21.3	2.60	0.450	8.5	7.8	-	11.8
FKM43.20A.□□.□□□□	9.0	36	2000	3.9	15.7	1.88	2.30	9.7	14.5	1.720	16.7	11.7	18.4	36.0
FKM43.30A.□□.□□□□	9.0	36	3000	6.2	25	2.82	1.45	14.5	6.2	0.755	16.7	11.7	-	23.2
FKM43.40A.□□.□□□□	9.0	36	4000	9.4	38	3.77	0.95	19.4	2.4	0.315	16.7	11.7	-	15.2
FKM44.20A.□□.□□□□	11.6	47	2000	4.6	19	2.4	2.52	7.4	14.51	1.720	16.7	11.7	-	40.3
FKM44.30A.□□.□□□□	11.6	47	3000	8.2	33	3.6	1.41	11.2	4.20	0.540	16.7	11.7	-	22.5
FKM44.30A.□□.□□□□.2	11.6	47	3000	7.0	28	3.6	1.65	11.1	6.16	0.755	16.7	11.7	-	26.4
FKM62.30A.□□.□□□□	8.9	35	3000	7.1	28	2.8	1.25	14.4	7.20	0.770	16.0	11.9	-	20.0
FKM62.40A.□□.□□□□	8.9	35	4000	9.3	37	3.7	0.95	19.1	4.10	0.440	16.0	11.9	-	15.3
FKM63.20A.□□.□□□□	12.5	51	2000	5.3	21.3	2.6	2.35	12.1	13.2	0.935	29.5	17.1	-	37.6
FKM63.30A.□□.□□□□	12.5	51	3000	10.3	40.6	3.9	1.21	18.1	3.8	0.280	29.5	17.1	-	19.3
FKM64.20A.□□.□□□□	16.5	66	2000	6.5	26	3.4	2.53	9.3	13.16	0.935	29.5	17.1	-	40.6
FKM66.20A.□□.□□□□	23.5	94	2000	10.5	42	4.9	2.23	9.5	4.60	0.315	43.0	22.3	-	35.8
FKM66.20A.□□.□□□□.2	23.5	94	2000	9.4	37	4.9	2.50	9.5	8.82	0.410	43.0	22.3	-	40.0

1. Motor inertia without brake.

2. Motor mass without brake.

Note. In the combinations shown in bold letters, the drive will limit its peak current automatically so as not to damage the motor.

Technical data of non-ventilated synchronous FKM motors with "F" winding (220 V AC).

Non-ventilated motors	Stall torque		Rated speed	Stall current	Peak current	Calculation power	Torque constant	Acceleration time	Inductance per phase	Resistance per phase	Inertia ¹		Mass ²	Drive peak torque		
	Mo	Mp									nN	Io		Imax	Pcal	kt
	Nm	Nm	rev/min	Arms	Arms	kW	Nm/Arms	ms	mH	Ω	kg·cm ²	kg	Nm	Nm	Nm	
FKM21.60F.□□.□□□□	1.7	7	6000	4.7	19	1.1	0.36	14.4	2.6	0.885	1.6	4.2	3.6	7.0	-	
FKM22.30F.□□.□□□□	3.2	13	3000	4.5	18	1.0	0.74	7.0	4.6	1.100	2.9	5.3	7.4	13.0	-	
FKM22.50F.□□.□□□□	3.2	13	5000	7.2	29	1.7	0.45	11.7	1.7	0.425	2.9	5.3	-	9.0	13.0	
FKM42.30F.□□.□□□□	6.3	25	3000	8.5	34	2.0	0.74	10.7	2.6	0.450	8.5	7.8	-	14.8	22.2	
FKM42.45F.□□.□□□□	6.3	25	4500	12.4	50	3.0	0.51	16.0	1.2	0.210	8.5	7.8	-	18.2	25.0	
FKM43.30F.□□.□□□□	9.0	36	3000	13.8	55.4	2.8	0.65	14.5	1.2	0.150	16.7	11.7	-	-	19.5	
FKM44.30F.□□.□□□□	11.6	47	3000	15.6	62	3.6	0.74	11.2	1.2	0.150	16.7	11.7	-	-	22.2	
FKM62.30F.□□.□□□□	8.9	35	3000	13.1	52	2.8	0.68	14.4	2.1	0.225	16.0	11.9	-	-	20.4	
FKM62.40F.□□.□□□□	8.9	35	4000	16.4	66	3.7	0.54	19.1	1.3	0.180	16.0	11.9	-	-	16.2	
FKM63.20F.□□.□□□□	12.5	51	2000	11.7	46.6	2.6	1.06	12.1	2.7	0.205	29.5	17.1	-	-	31.8	
FKM63.30F.□□.□□□□	12.5	51	3000	16.6	66.4	3.9	0.75	18.1	1.3	0.100	29.5	17.1	-	-	22.5	
FKM64.20F.□□.□□□□	16.5	66	2000	14.3	57	3.4	1.15	9.35	2.7	0.205	29.5	17.1	-	-	34.5	
FKM64.30F.□□.□□□□	16.5	66	3000	20.0	80	5.1	0.82	14.0	1.3	0.145	29.5	17.1	-	-	24.6	
FKM66.20F.□□.□□□□	23.5	94	2000	19.2	76.8	4.9	1.22	9.57	0.8	0.135	43.0	22.3	-	-	36.6	

1. Motor inertia without brake.

2. Motor mass without brake.

Note. In the combinations shown in bold letters, the drive will limit its peak current automatically so as not to damage the motor.

Dimensions

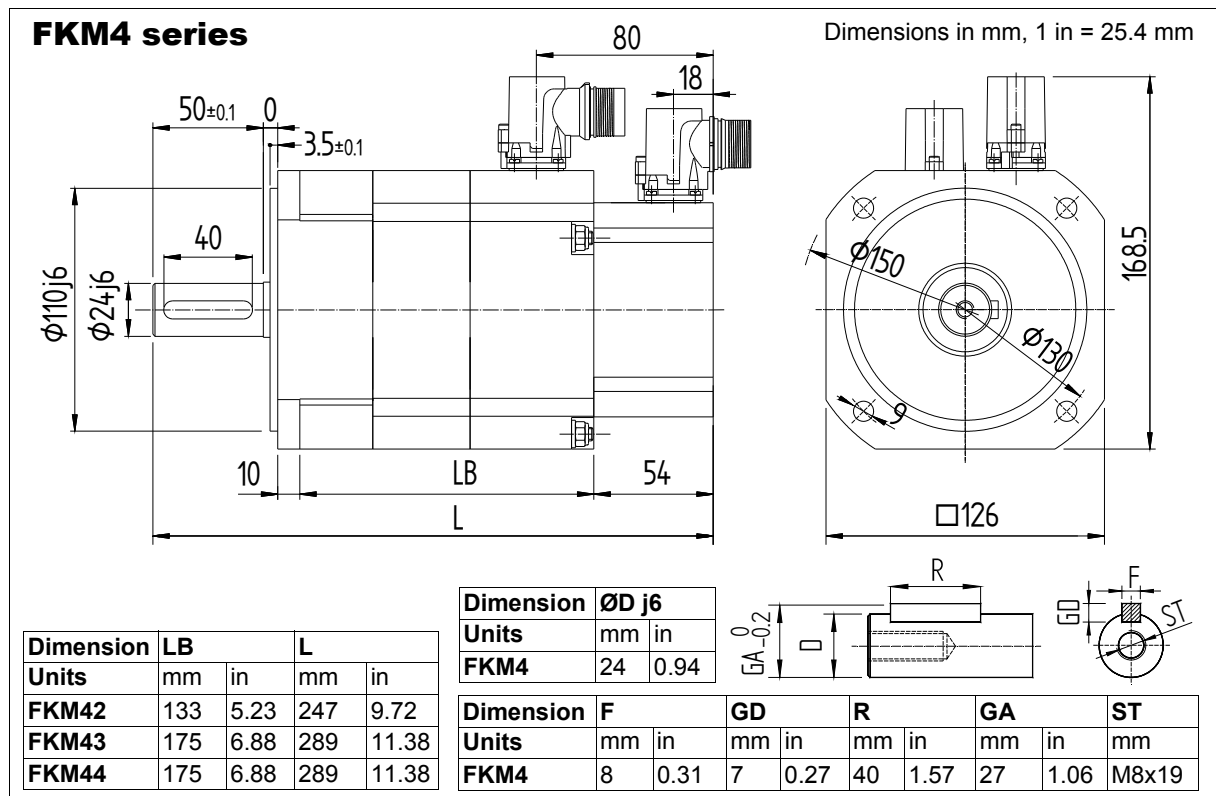
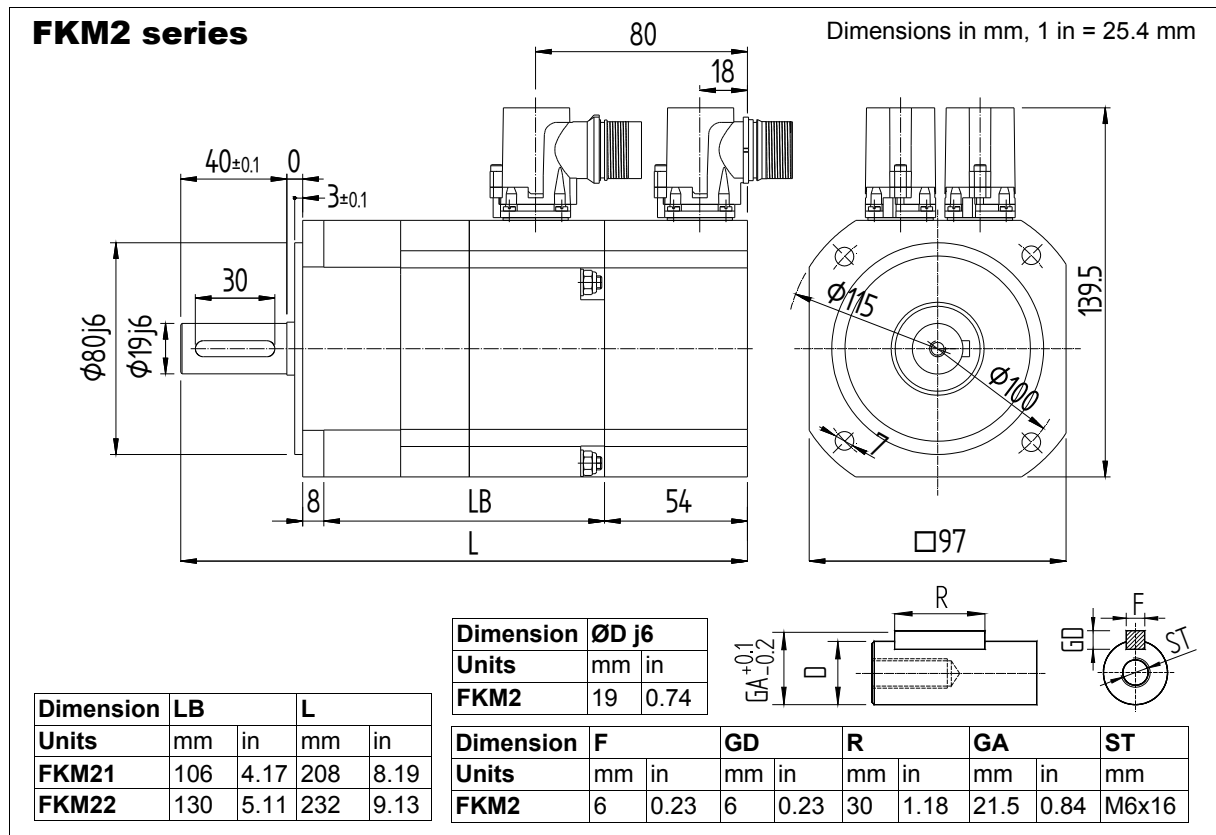

FKM6 series

Dimensions in mm, 1 in = 25.4 mm

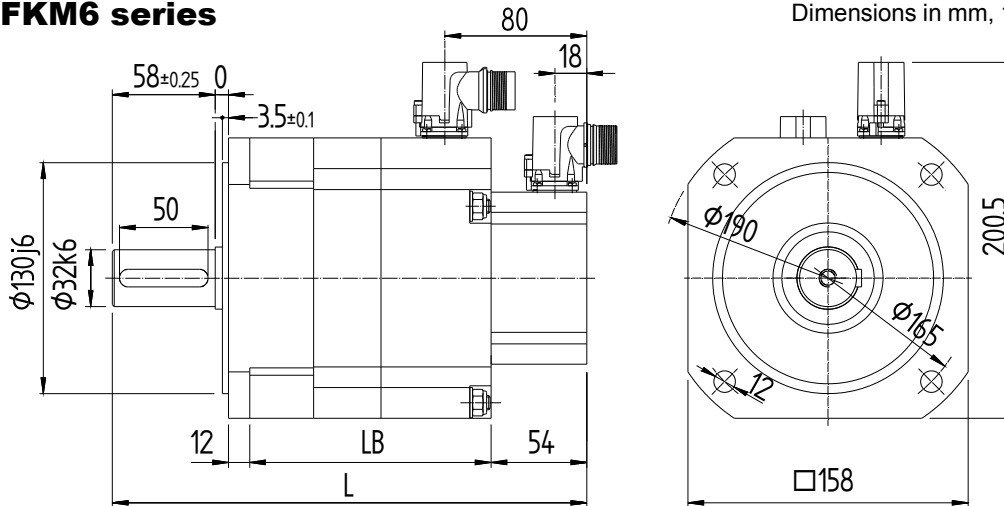

Dimension	LB		L	
	mm	in	mm	in
FKM62	136	5.35	260	10.24
FKM63	172	6.77	296	11.65
FKM64	172	6.77	296	11.65
FKM66	208	8.18	332	13.07

Dimension	ØD k6	
	mm	in
FKM6	32	1.26

Dimension	F		GD		R		GA		ST
	mm	in	mm	in	mm	in	mm	in	mm
FKM6	10	0.39	8	0.31	50	1.96	35	1.37	M10x22

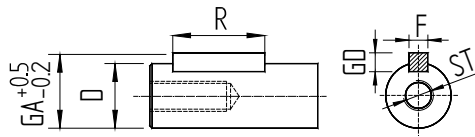

Power connectors and encoder output

It includes the connectors of the brake itself (pins 4 and 5). A voltage between 22 and 26 V DC releases the shaft. When installing the motor, verify that the brake releases the shaft completely before turning it for the first time. Connecting the motor windings in the order indicated on the connector (U, V, W), the shaft will turn clockwise (CWR, **C**lock-**W**ise **R**otation).

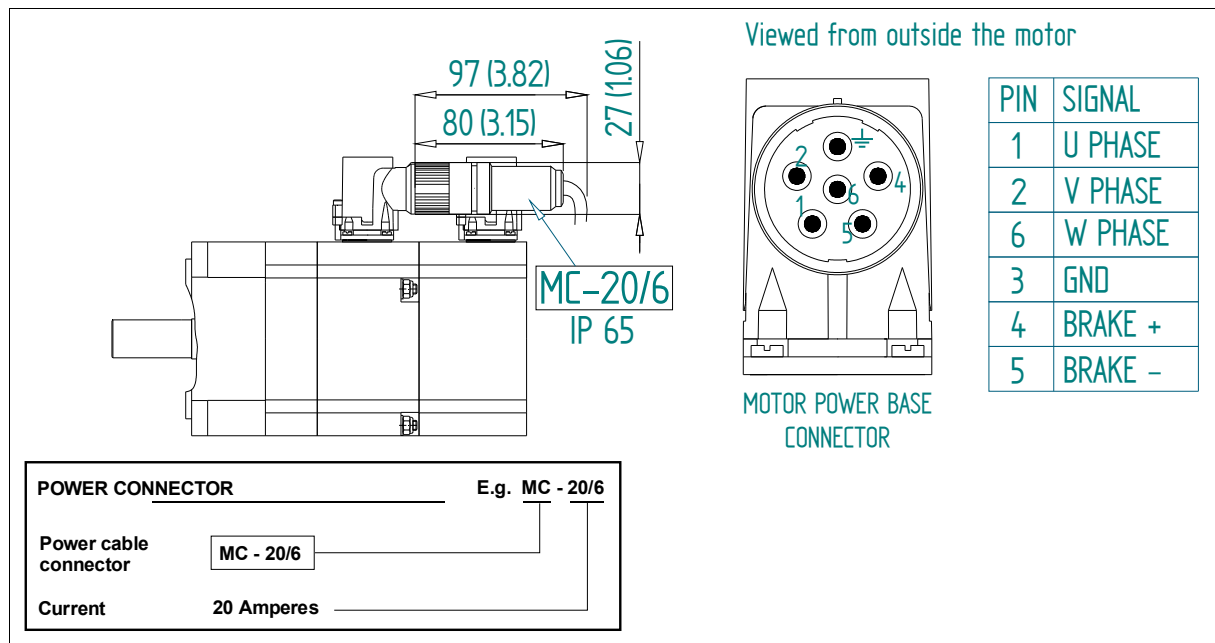

Pins of 9 and 10 of the connector of the incremental TTL encoder correspond to the PTC KTY84-130 thermistor with polarity (-) and (+) respectively used to monitor motor overheating.

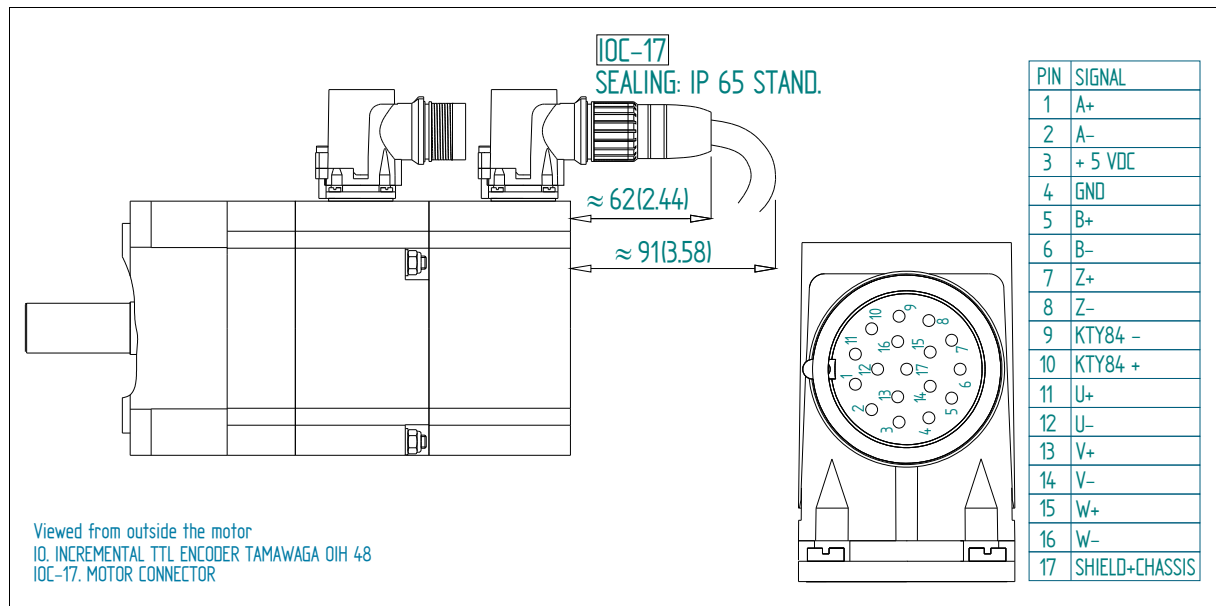

Pins of 3 and 4 of the connector of the SinCos encoder correspond to the PTC KTY84-130 thermistor with polarity (-) and (+) respectively used to monitor motor overheating.

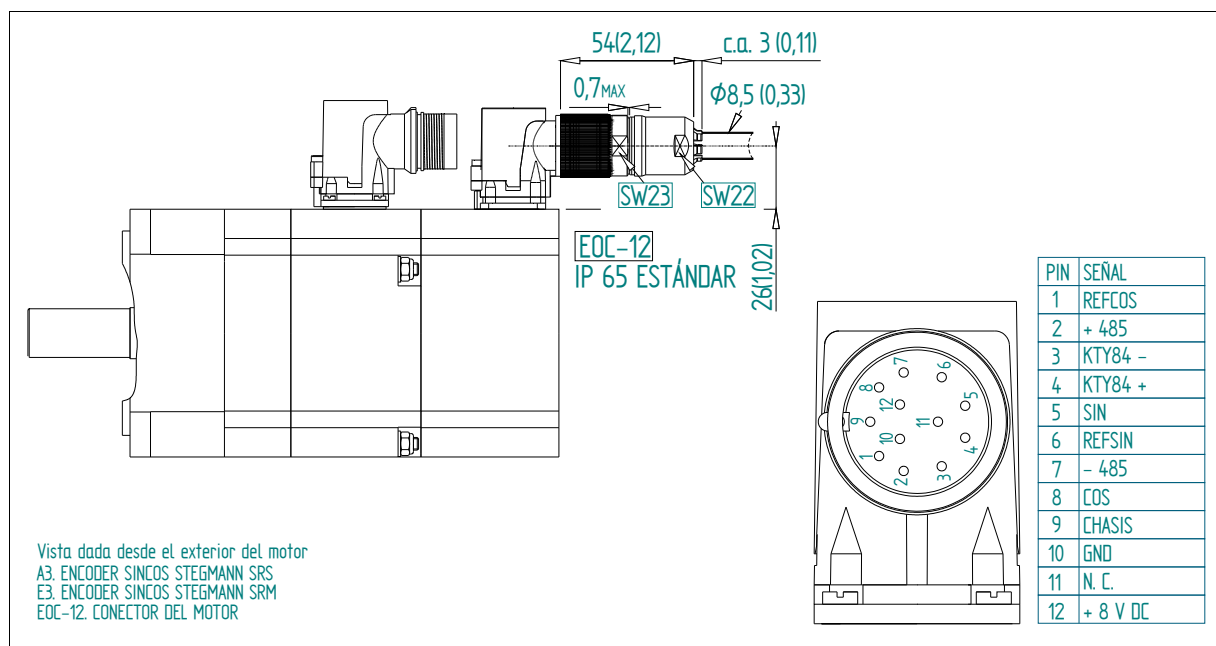

Brake characteristics

FKM motors have an optional brake that applies friction to the shaft. Its purpose is to immobilize or lock vertical axes, not to brake a moving axis.

Its main characteristics depending on the type of brake are:

Motor	Holding torque	Power consumption	On/Off time	Range of releasing voltage	Inertia	Mass
Units	N·m (lbf·ft)	W (hp)	ms	V DC	kg·cm ²	kg (lbf)
FKM2	4.5 (3.32)	12 (0.016)	7/35	22-26	0.18	0.30 (0.66)
FKM4	9.0 (6.64)	18 (0.024)	7/40	22-26	0,54	0.48 (1.06)
FKM6	18.0 (13.28)	24 (0.032)	10/50	22-26	1.66	0.87 (1.92)

Note. Maximum speed for all of them is 10000 rev/min.



WARNING.

NEVER use this brake to stop a moving axis!



WARNING.

- The brake must never exceed its maximum turning speed.
 - Voltage between 22 and 26 V DC releases the shaft. Make sure that no voltage over 26 V DC is applied that prevents the shaft from turning.
 - When installing the motor, make sure that the brake fully releases the shaft before making it turn for the first time.
-

Sales reference

FKM □□ . □□□ . □□□ . □□□□ . □ - K □□													
FAGOR SYNCHRONOUS MOTOR													
SIZE	2, 4, 6												
LENGTH	1, 2, 3, 4, 6												
RATED SPEED	<table border="0"> <tr> <td>20</td> <td>2000 rev/min</td> <td>45</td> <td>4500 rev/min</td> </tr> <tr> <td>30</td> <td>3000 rev/min</td> <td>50</td> <td>5000 rev/min</td> </tr> <tr> <td>40</td> <td>4000 rev/min</td> <td>60</td> <td>6000 rev/min</td> </tr> </table>	20	2000 rev/min	45	4500 rev/min	30	3000 rev/min	50	5000 rev/min	40	4000 rev/min	60	6000 rev/min
20	2000 rev/min	45	4500 rev/min										
30	3000 rev/min	50	5000 rev/min										
40	4000 rev/min	60	6000 rev/min										
WINDING	<table border="0"> <tr> <td>A</td> <td>400 V AC</td> </tr> <tr> <td>F</td> <td>220 V AC</td> </tr> </table>	A	400 V AC	F	220 V AC								
A	400 V AC												
F	220 V AC												
FEEDBACK TYPE	<table border="0"> <tr> <td>I0</td> <td>Incremental encoder (2500 ppt)</td> </tr> <tr> <td>A3</td> <td>Absolute multi-turn SinCos encoder (1024 ppt)</td> </tr> <tr> <td>E3</td> <td>SinCos encoder (1024 ppt)</td> </tr> </table>	I0	Incremental encoder (2500 ppt)	A3	Absolute multi-turn SinCos encoder (1024 ppt)	E3	SinCos encoder (1024 ppt)						
I0	Incremental encoder (2500 ppt)												
A3	Absolute multi-turn SinCos encoder (1024 ppt)												
E3	SinCos encoder (1024 ppt)												
FLANGE & SHAFT	<table border="0"> <tr> <td>0</td> <td>With keyway (half-key balancing)</td> </tr> <tr> <td>1</td> <td>Cylindrical (with no keyway)</td> </tr> <tr> <td>2</td> <td>Shaft with key and seal</td> </tr> <tr> <td>3</td> <td>Keyless shaft with seal</td> </tr> </table>	0	With keyway (half-key balancing)	1	Cylindrical (with no keyway)	2	Shaft with key and seal	3	Keyless shaft with seal				
0	With keyway (half-key balancing)												
1	Cylindrical (with no keyway)												
2	Shaft with key and seal												
3	Keyless shaft with seal												
BRAKE OPTION	<table border="0"> <tr> <td>0</td> <td>Whitout brake</td> </tr> <tr> <td>1</td> <td>With standard brake (24 V DC)</td> </tr> </table>	0	Whitout brake	1	With standard brake (24 V DC)								
0	Whitout brake												
1	With standard brake (24 V DC)												
CONNECTION	<table border="0"> <tr> <td>0</td> <td>Rotating angled connectors</td> </tr> <tr> <td>1</td> <td>Cable output without connectors</td> </tr> <tr> <td>9</td> <td>Special</td> </tr> </table>	0	Rotating angled connectors	1	Cable output without connectors	9	Special						
0	Rotating angled connectors												
1	Cable output without connectors												
9	Special												
	2 Optimized for ACSD-16H												
SPECIAL CONFIGURATION	K												
SPECIFICATION	<table border="0"> <tr> <td>01</td> <td>→ ZZ</td> </tr> <tr> <td colspan="2">Only when it has a special configuration (K)!</td> </tr> </table>	01	→ ZZ	Only when it has a special configuration (K)!									
01	→ ZZ												
Only when it has a special configuration (K)!													

NOTE. Motors with “F” winding may have an incremental I0 encoder. The rest of the feedback devices will only be available on motors with “A” winding.

A. C. SERVODRIVE

Introduction

The MCS family is a compact speed servo drive family for controlling synchronous AC brushless motors.

It has two series depending on the supply voltage they can be connected to: Thus, we will refer to:

MCS (H series) if the power supply voltage is 400 V AC

MCS (L series) if the power supply voltage is 220 V AC

where each of them will have the following models depending on their peak current:

- ❑ For the “MCS-H” series:
MCS-04H
MCS-08H
MCS-16H
with peak currents of 4, 8 and 16 Arms.
- ❑ For the “MCS-L” series:
MCS-05L
MCS-10L
MCS-20L
MCS-30L
with peak currents of 5, 10, 20 and 30 Arms.

General characteristics

Their main characteristics are:

- ❑ Three phase power supply.
- ❑ Dynamic braking in case of mains failure.
- ❑ PWM IGBTs.
- ❑ 2500-line incremental TTL encoder feedback or 1Vpp sinusoidal encoder.
- ❑ Programmable encoder simulator output.
- ❑ RS-422 serial line.
- ❑ Two logic inputs for motor control: Speed Enable and Drive Enable.
- ❑ One programmable logic input.
- ❑ One programmable logic output.
- ❑ Two programmable logic outputs.
- ❑ Integrated functions.
- ❑ “On-line” parameter editing.
- ❑ Integrated programming module.
- ❑ Typical protections in velocity drives.
- ❑ RS-232, RS-422 and RS-485 communications interfaces.
- ❑ Communication protocol: ModBus.

Dimensions

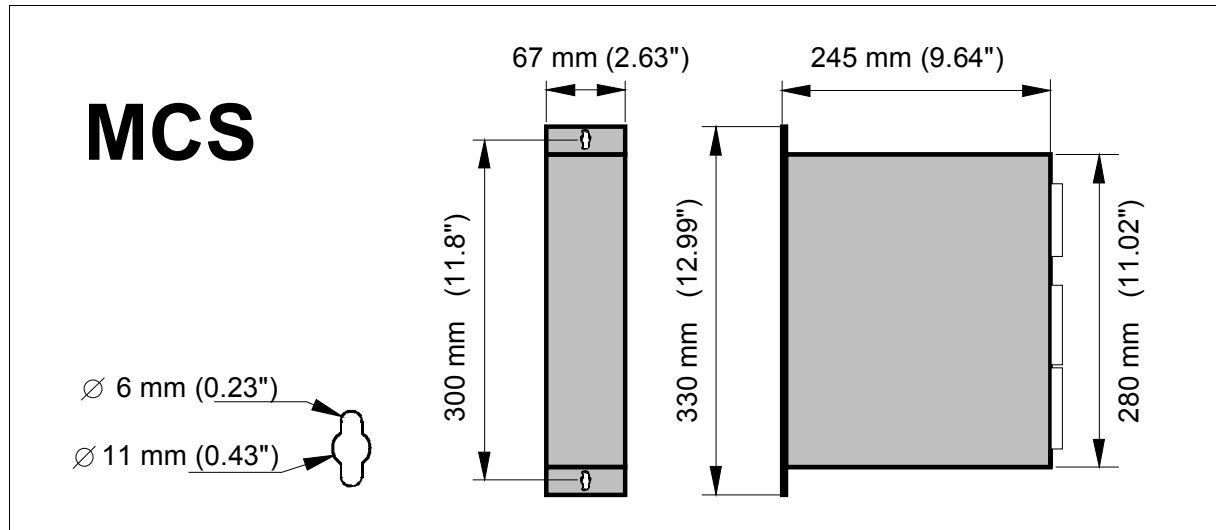

Technical data

	220 V - L series -				400 V - H series -		
	05	10	20	30	04	08	16
Rated output current (Arms)	2.5	5	10	15	2	4	8
Peak current (0.5 s) (Arms)	5	10	20	30	4	8	16
Power supply	3 AC 220/240 V \pm 10 % 50/60 Hz \pm 10 %				3 AC 400/460 V \pm 10 % 50/60 Hz \pm 10 %		
Consumption (Arms)	5.6	11.1	22.2	33.3	4.4	8.9	16.7
¹ On single-phase models	(9.5) ¹	(18.5) ¹					
Over-voltage protection	430 V DC				803 V DC		
Frequency	Lower than 600 Hz						
Internal Ballast (Ω)	112	56	28	18	132	132	66
Power of the internal Ballast	150 W						
Ballast trigger	416 V DC				780 V DC		
Thermal protection of the heatsink	90°C (194°F)						
Operating temperature	5°C/45°C (41°F/113°F)						
Storage temperature	-20°C/60°C (-4°F/140°F)						
Protection degree	IP 20 ^{a)}						
Module dimensions	67 x 280 x 245 mm (2.48 x 11.8 x 9.05 in)						
Module mass	3.85 kg (8.5 lb)						

a) IP 20 means that it is protected against objects of a diameter larger than 12.5 mm, but not against water splashes. Therefore, the unit must be mounted inside an electrical cabinet..



INFORMATION. ^{1/} Modules MCS-05L and MCS-10L (220 VAC) may be supplied with a single-phase power voltage.

Connectors

Power terminals

POWER INPUTS L1, L2, L3. Mains input terminals.

POWER OUTPUTS U, V, W. Output terminals for the voltage applied to the motor. Current control with PWM on a carrier frequency of 8 kHz. When connecting to the motor, watch the matching of phases U-U, V-V and W-W.

L+, Ri, Re. Terminals to configure and connect the external ballast resistor.

CONTROL POWER INPUTS L1, L2, GROUND (X3). Input terminals for the voltage supply of the drive's control circuits from mains. The maximum cable section at these power terminals is 2.5 mm². Total isolation between the power and the control circuits.

ACTIVATION OF THE INTERNAL FAN. The internal fan that cools the drive's power elements starts when enabling the Drive Enable signal. The fan will stop when the heatsink temperature is lower 70 °C since the Drive Enable signal is turned off. This method decreases the fan's operating time, thus increasing its useful life.

Control signals

Voltage ± 12 V (pins 1, 2 and 3 of X1). Output of an internal power supply so the user can easily generate a command signal. It offers a maximum current of 20 mA limited internally.

Velocity command (pins 4, 5 and 6 of X1). Velocity command input for the motor. It admits a range ±10 V and offers an impedance of 22 kΩ.

Programmable analog input (pins 4 and 7 of X1). Input of the analog command used by some integrated function. It offers an impedance of 10 kΩ.

Programmable analog output 1 (pins 8 and 10 of X1). Voltage range of ± 10 V.

Programmable analog output 2 (pins 9 and 10 of X1). Voltage range of ±10V. They offer an analog value of a set of internal variables of the drive.

Programmable digital output 1 (pins 1 and 2 of X2). Optocoupled open collector output that reflects the output of some integrated functions.

Common (pin 5 of X2). Reference point for the following:

Drive Enable (pin 4 of X2). At 0 V DC no current can circulate through the motor and it has no torque.

Speed Enable (pin 3 of X2). At 0 V DC, it forces an internal zero velocity command.

NOTE. These control signals are activated with + 24 V DC.

Drive Ok (pins 6 and 7 of X2). Relay contact that closes when the internal status of the drive control is OK. It must be included in the electrical maneuver.

Programmable digital input (pins 8 and 9 of X2). Digital input that is used as input to some integrated functions (0 and + 24 V). By default, it is selected as error reset.

Motor feedback input + motor temp. sensor. Input of the encoder signals installed on the motor for “position+velocity” feedback and of the temperature sensor of the motor.

Encoder simulator output. Outputs of those same encoder signals, divided by the preset factor, for closing the position loop at the CNC.

NOTE. The maximum cable section at these terminals is 0.5 mm². See the chapter on installation.

RS232/RS422/RS485 communications. Connector used to communicate with other equipment with the RS-232, RS-422 or RS-485 serial line.

Programming module

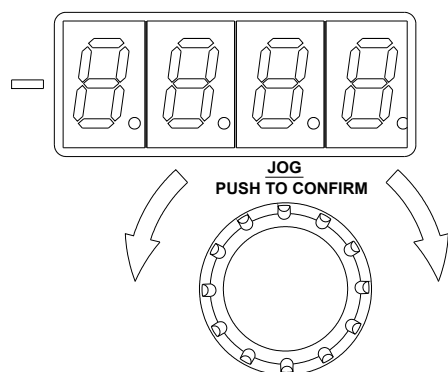

The programming module (present on MCS model) has four numeric displays of 7 segments, a sign indicator and a rotary decoder with a push button for confirmation incorporated on the knob itself.

The rotating direction may be:

► **Clockwise** being possible to:

- ❑ To scroll through the list of parameters, variables and commands and display a particular one.

- ❑ To increase its value (if parameters).

► **Counterclockwise** being possible to:

- ❑ To decrease its value.

The push-button may be pressed in two ways:

- ❑ Short push (C).

- ❑ Long push (L).

The following diagram shows the sequence to follow to display parameters, variables, commands; modify the value of a parameter, confirm its new value, ...

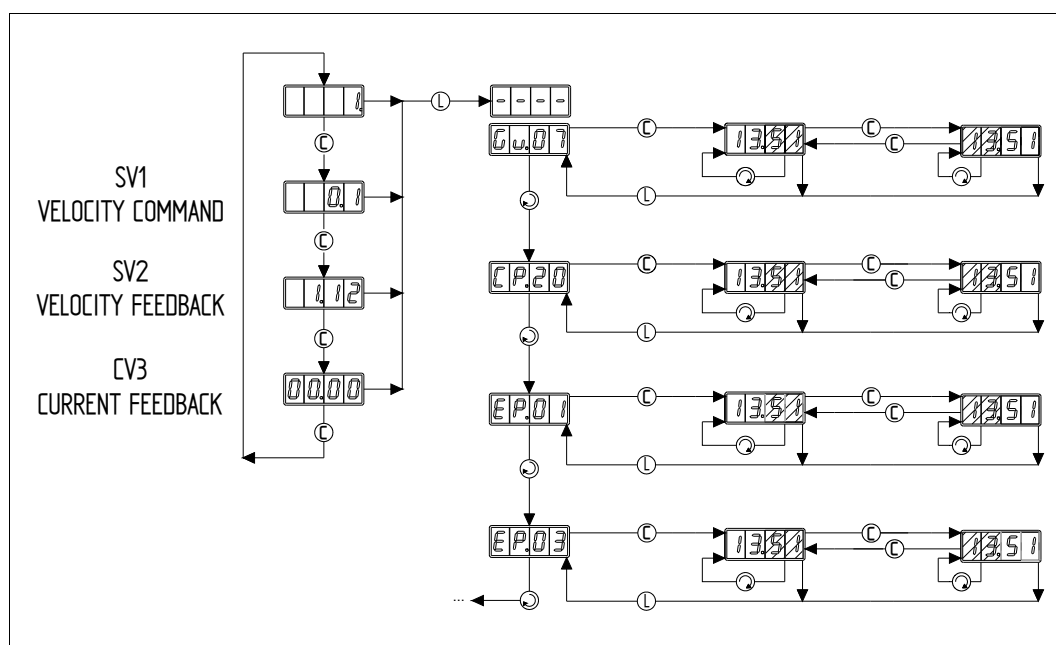

There are also a set of variables and certain commands of special characteristics whose meaning and sequences to follow are described in section “**Initialization and setup**” in this manual.

Interpretation of the symbols used in some diagrams of this manual.

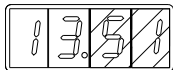

Blinking status of the two rightmost digits of the display.

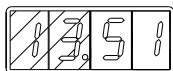

Blinking status of the two leftmost digits of the display.



Long push on the programming module.



Short push on the programming module.



Rotary decoder on the programming module.

Front panel and pinout of the connectors

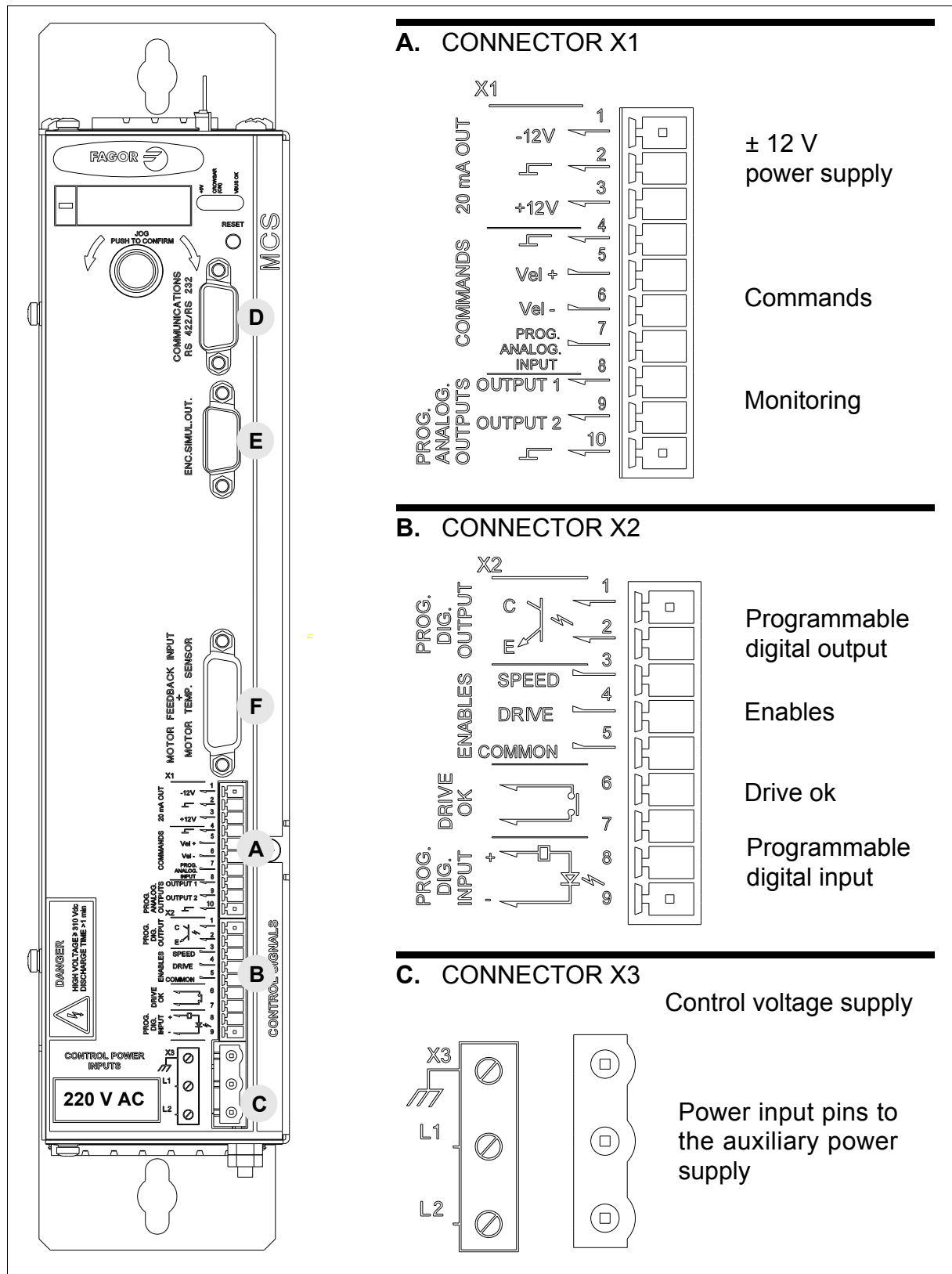

A. CONNECTOR X1

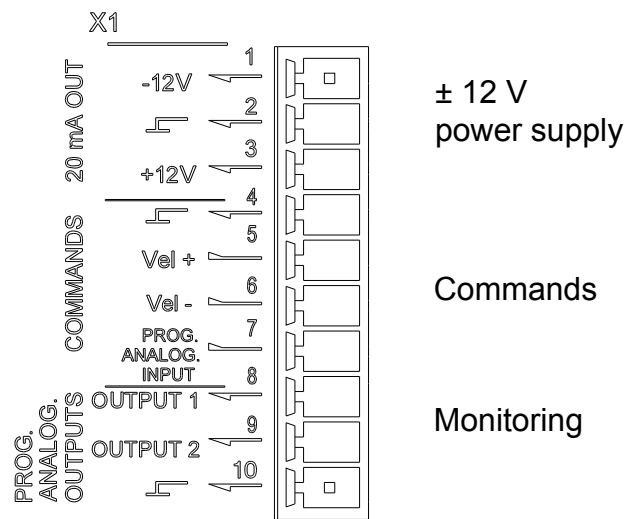

B. CONNECTOR X2

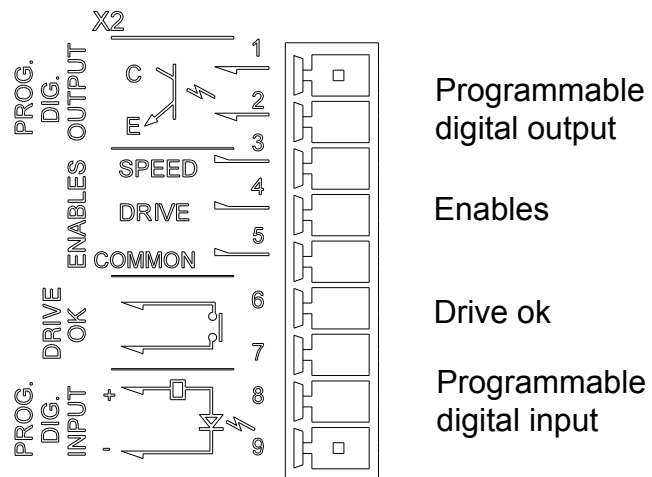

C. CONNECTOR X3

Control voltage supply

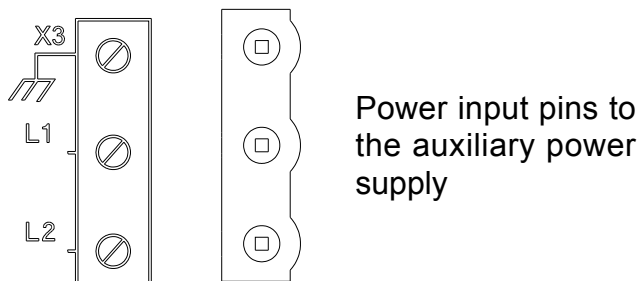

NOTE. The label 220 V AC will indicate 400 V AC on the corresponding models.

D. Communications connector

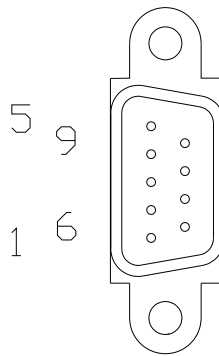

Pin	Signal	Function
1	N.C.	Not connected
2	R x D	R x D (232)
3	T x D	T x D (232)
4	+ 5 V	Voltage supply
5	GND	GND
6	T x D +	T x D + (422)
7	T x D -	T x D - (422)
8	R x D +	R x D + (422) T x D / R x D + (485)
9	R x D -	R x D - (422) T x D / R x D - (485)
	CHASSIS	Screws

E. Output connector of the encoder simulator

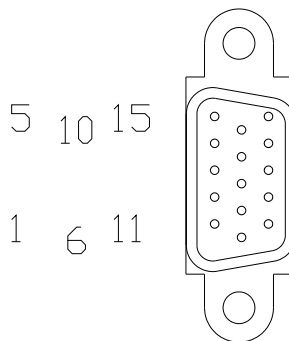

Pin	Signal	Function
1	A +	A + signal
2	A -	A - signal
3	B +	B + signal
4	B -	B - signal
5	Z +	Z + signal
6	Z -	Z - signal
7	+ 485	RS485 serial line transmission signal
8	- 485	
9	N.C.	Not connected
10	N.C.	Not connected
11	GND	0 volts
12	REFCOS	Cosine signal ref. level
13	COS	Encoder cosine signal
14	REFSIN	Sine signal ref. level
15	SIN	Encoder sine signal
	CHASSIS	Screws

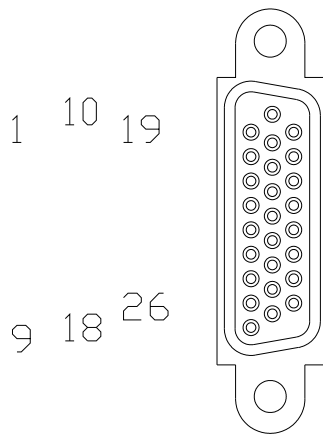

F. Input connector of the motor feedback and temperature sensor



Pin	Signal	Function
1	A+	A+ signal
2	B+	B+ signal
3	Z+	Z+ signal
4	U-	Phase switching U -
5	W-	Phase switching W -
6	V-	Phase switching V -
7	N.C.	Not connected
8	N.C.	
9	N.C.	
10	A-	A- signal
11	B-	B- signal
12	Z-	Z- signal
13	U+	Phase switching U+
14	W+	Phase switching W+
15	V+	Phase switching V+
16	N.C.	Not connected
17	SELSEN1	Information of the installed sensor given to the drive via hardware
18	SELSEN2	
19	+ 485	RS-485 serial line for SinCos or SinCoder encoder
20	- 485	
21	KTY -	Thermal sensor KTY84-130 of the motor
22	KTY+	
23	+ 8 V	Voltage supply for SinCos or SinCoder encoder
24	+ 5 V	Supply voltage for the incremental encoder
25	GND	0 volts
26	CHASSIS	Pin
	CHASSIS	Screws

Characteristics plate

Examples of the specs plate that comes with each FAGOR MCS digital drive.

		Fagor Automation S. Coop.(Spain) AC SERVODRIVE			
MODEL: MCS-10 L S.N.: 22-01090003		INPUT : 3 x 220 VAC / 50-60 Hz			
CTR 00A	POT 00A	VAR 00A	FR	I _o 5 A I _{max} 10 A	W: 3.8 kg

CTR, POT, VAR and FR indicate manufacturing related aspects (hardware design versions) that are useful for technical consultations and repairs.

Sales reference

Codes of the sales reference of FAGOR drives.

MCS DIGITAL SERVO DRIVE		Example: MCS -		05	L
MODEL	MCS				
CURRENT		Rated	Peak (0.5 s)		
	05	2.5 A	5 A		
	10	5 A	10 A		
	20	10 A	20 A		
	30	15 A	30 A		
SUPPLY VOLTAGE		220 V AC			

MCS DIGITAL SERVO DRIVE		Example: MCS -		04	H
MODEL	MCS				
CURRENT		Rated	Peak (0.5 s)		
	04	2 A	4 A		
	08	4 A	8 A		
	16	8 A	16 A		
SUPPLY VOLTAGE		400 V AC			

INSTALLATION

General considerations

At the motor

Remove the anti-corrosion paint of the shaft before mounting them on to the machine. The motor may be mounted as described in the first chapter (B5, V1 and V3).

Watch for the ambient conditions mentioned in the section on general characteristics and also:

- Mount it somewhere that is dry, clean and accessible for maintenance.

NOTE. Remember that the degree of protection is IP 64.

- It must be easily cooled.
- Avoid corrosive or flammable environments.
- Guard the motor with a cover if it is exposed to splashes.
- Use flexible coupling for direct transmission.
- Avoid radial and axial loads on the motor shaft.



MANDATORY: Do not hit the shaft when installing transmission pulleys or gears!

Use some tool that is supported in the threaded hole on the shaft to insert the pulley or the gear.

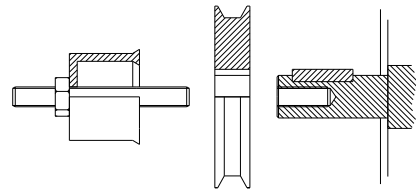

At the drive

Always install the module vertically and in an electrical cabinet that is clean, dry, free of dust, oil and other pollutants.

NOTE. Remember that the degree of protection is IP 20.

Never install it exposing it to flammable gases.

Avoid excessive heat and humidity.

Never exceed the room temperature of 45 °C (113 °F).

Avoid vibrations.

Respect the gaps inside the electrical cabinet to let air flow freely.

See the following figure.

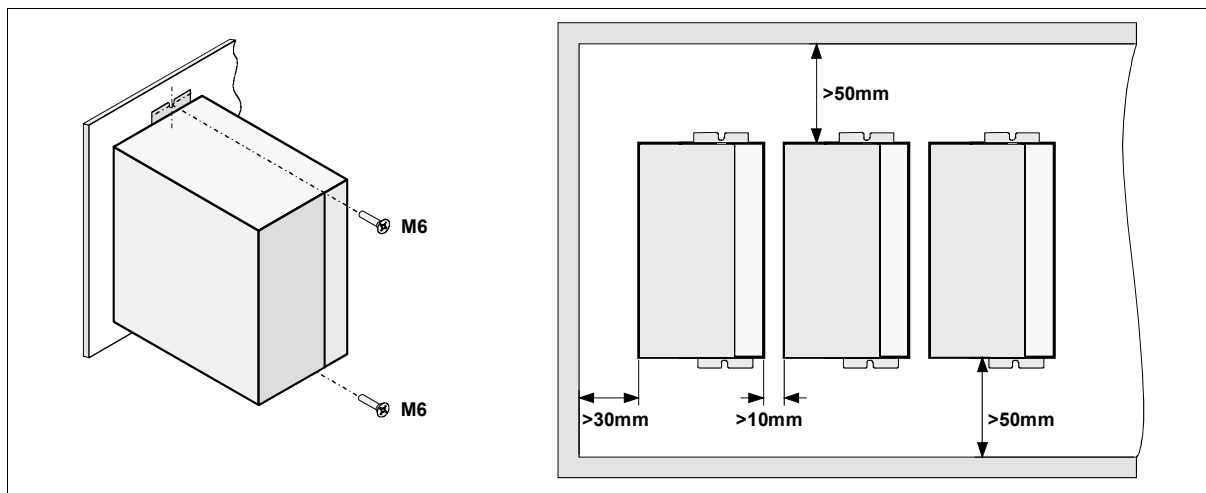

About the connection

All the cables must be shielded, to reduce the interference on the control of the motor due to the commutation of the PWM.

Connect the shield of the motor power cable to the chassis screw at the bottom of the module and it, in turn, to mains ground.

The command signal lines must be shielded twisted pairs.

Connect the shield to the voltage reference at the module, i.e. pins 2, 4 and 10 of X1.

NOTE. Keep the signal cables away from the power cables.

All the pins with the GND symbol (2, 4 and 10) are the same electrical point and are interchangeable.

Electrical connections

Basic interconnection diagram

See section, “Encoder feedback connection”

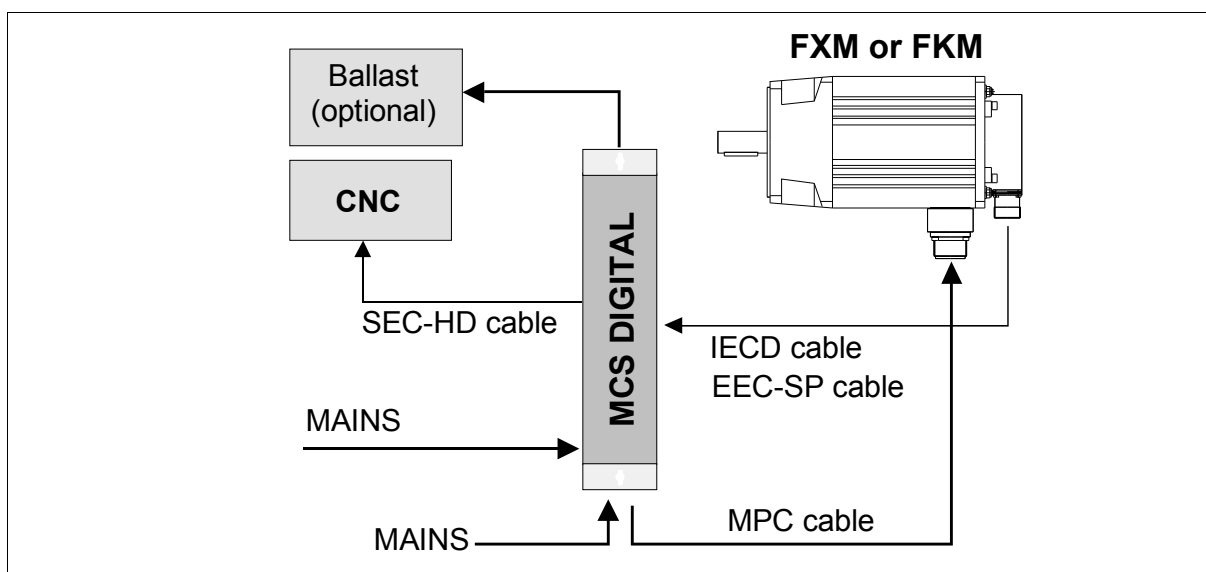

Power connection. Mains-Drive

The drive power supply must be three-phase, except in modules MCS-05L and MCS-10L that can also be single-phase. See parameter GP16.

NOTE. The use of a transformer is not a must.

THREE PHASE

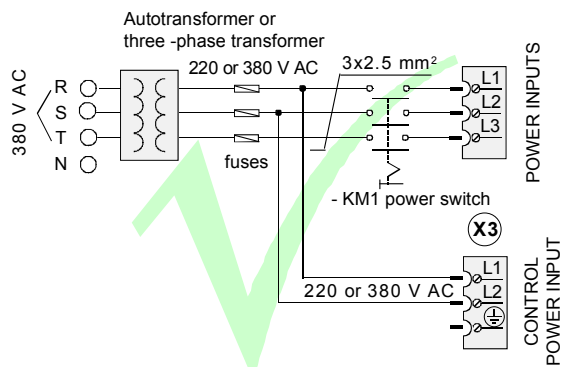

Warning. Never make this connection because there is a risk of destroying the module.

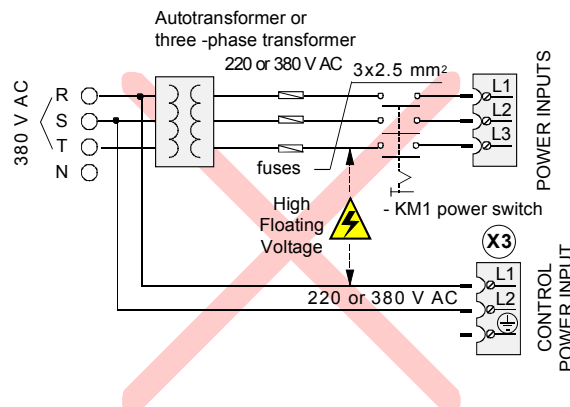

SINGLE - PHASE

Note. Only in MCS-05L and MCS-10L models

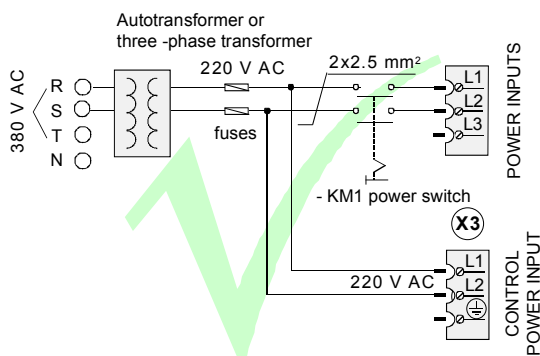

Warning. Never make this connection because there is a risk of destroying the module.

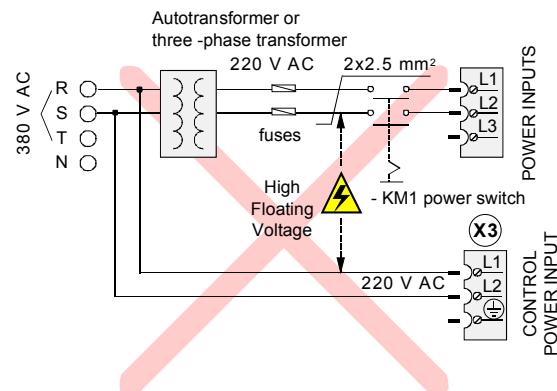

The table below shows the values recommended for the fuses shown in the previous figure. They are slow general purpose fuses. If they are installed on the mains input lines, their maximum currents will depend on the value of the mains voltage.

Model	Peak current (Arms)	Fuse (A)	
MCS-05L	05	04	
MCS-10L	10	08	
MCS-20L	20	16	
MCS-30L	30	25	
MCS-04H	04	04	
MCS-08H	08	08	
MCS-16H	16	16	

NOTE. A thermal switch may optionally replace the fuses.

Power cables

If the motor does not have a	If the motor has a brake
MPC-4x1.5	MPC-4x1.5+(2x1)
MPC-4x2.5	MPC-4x2.5+(2x1)

NOTE. The length of the MPC power cable must be specifically ordered (in meters).

Codes of the sales reference of FAGOR power cables.

MOTOR POWER CABLE	Ex. MPC 4 x 0.5
Motor Power Cable _____	
On motors without brake	
Nr of wires _____	
Section of each wire (mm ²) _____	
_____	Ex. MPC 4 x 0.5 + (2x1)
On motors with brake	
Nr of wires _____	
Section of each wire (mm ²) _____	
Nr of wires x section (for the brake) _____	

Connection of the monitoring and control signals

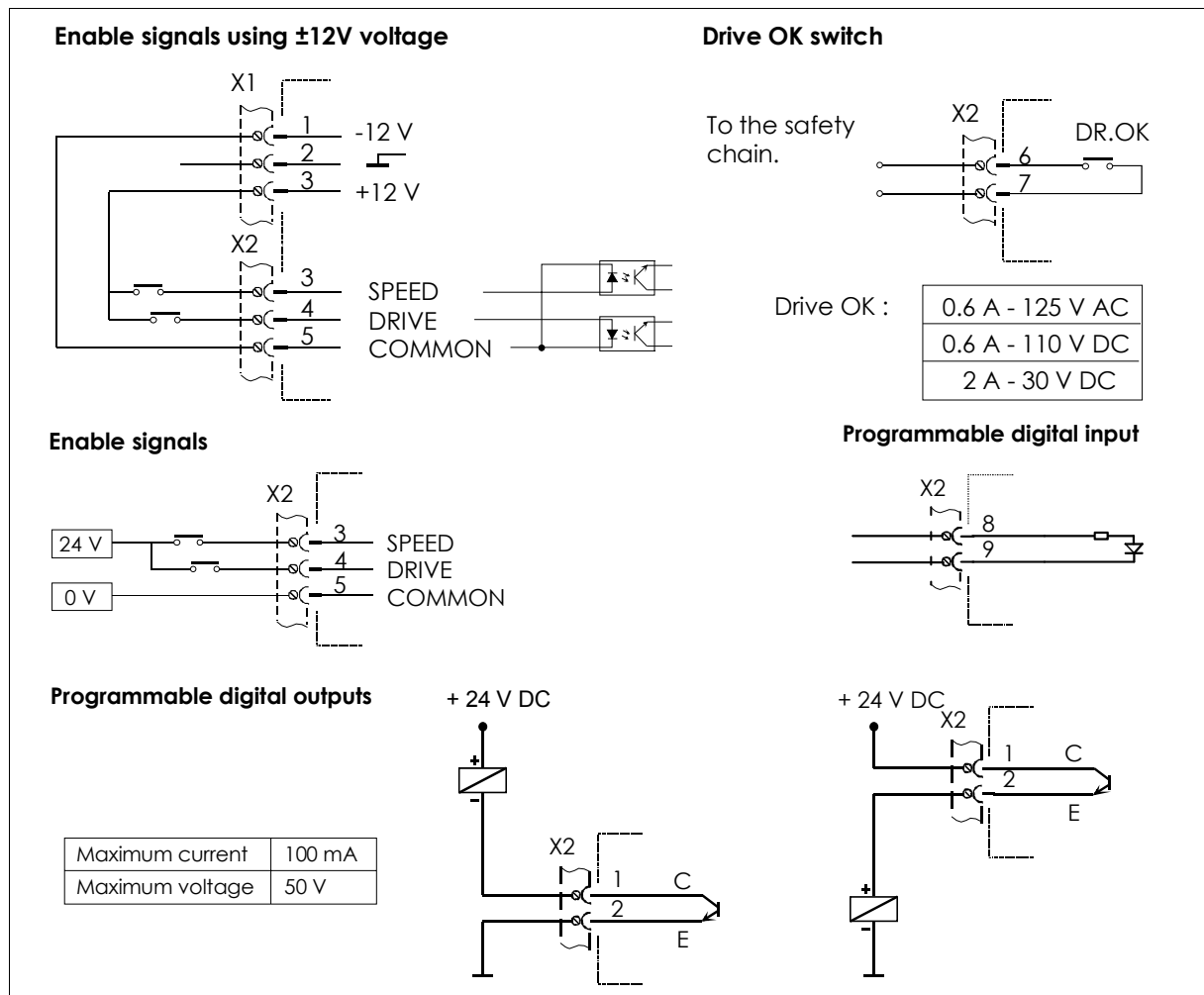

Encoder feedback connection

The signals generated by the encoder are taken to the ENCODER INPUT of the MCS drive. The MCS amplifies these signals and may divide their frequency. The division factor is given by the values of parameter EP1 (see parameter) and the sequence between A and B by parameter EP3. The MCS drive offers these signals by the connector ENC. SIMUL. OUT. The encoder must be mounted on to the motor shaft and cannot be installed anywhere else in the transmission chain.

The encoders that can be found on the motors depending on the series are:

At FXM servo motors
I0. Incremental TTL encoder (2500 ppt)
E1. SinCoder encoder (1024 ppt)
A1. Multi-turn SinCos encoder (1024 ppt)

At FKM servo motors
I0. Incremental TTL encoder (2500 ppt)
E3. SinCos encoder (taper shaft) (1024 ppt)
A3. Multi-turn SinCos encoder (1024 ppt)

With motor feedback E1 or E3, the output of the encoder simulator multiplies by 4 the number of pulses of the encoder ($1024 \times 4 = 4096$ ppt). This (4096) is the highest value to be set in EP1. Note that it may be programmed (it is not a fixed value).

Cabling

FAGOR provides these full connections (cables+connectors): **SEC-HD, IECD and EEC-SP.**

Encoder simulator connecting cable, SEC-HD

Depending on motor feedback, the drive can generate a set of signals that simulate those of a TTL encoder attached to the rotor of the motor. The SEC-HD cable transfers these signals from the drive to the 8055/55i CNC.

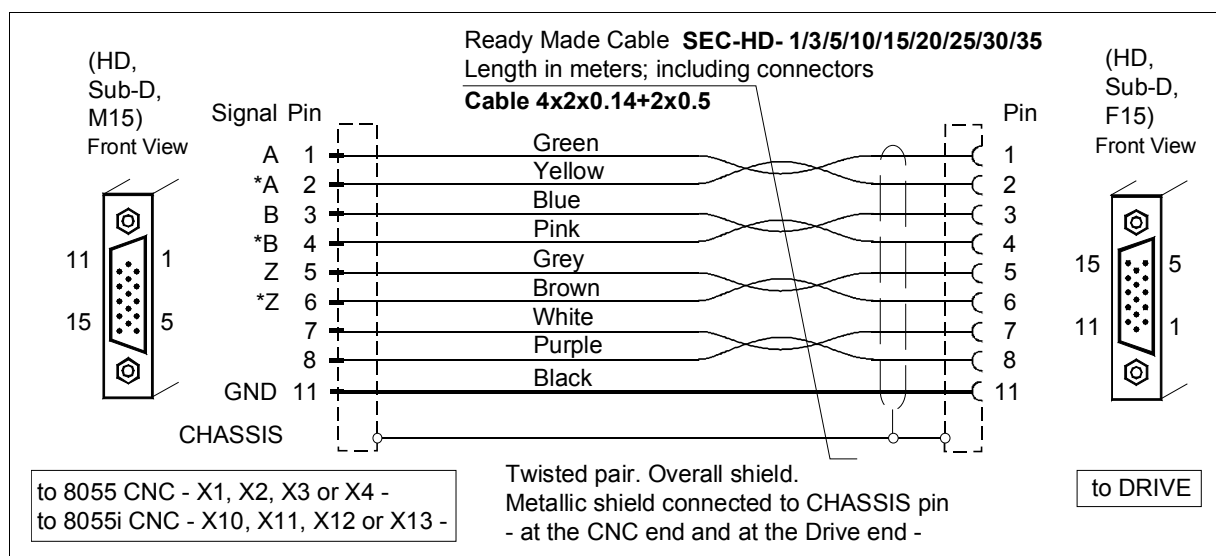

TTL encoder connecting cable, IECD

The IECD cable transfers the motor feedback signals from the incremental TTL encoder to the drive.

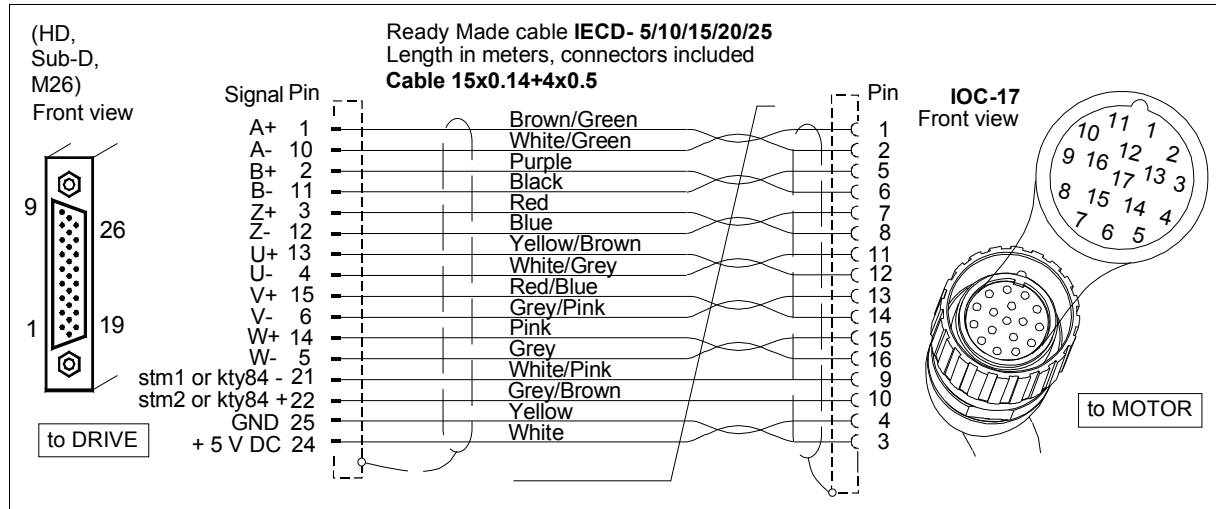

Sinusoidal encoder connecting cable, EEC-SP

The EEC-SP cable transfers the motor feedback signals from the sinusoidal encoder to the drive. It has overall shield and shielded twisted pairs. This cable has overall shield and shielded twisted pairs.



INFORMATION. Note that type I and II of the EEC-SP extension cables are the same except the color of their wires. The user must check which one of them matches the one being installed.

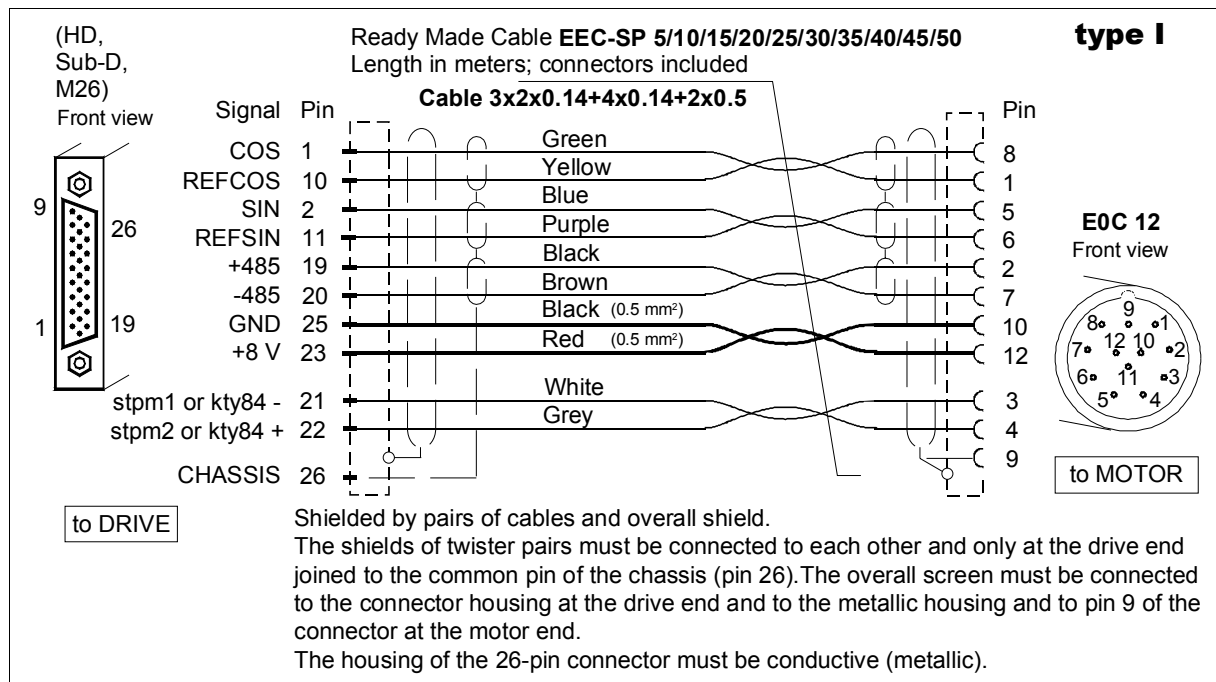

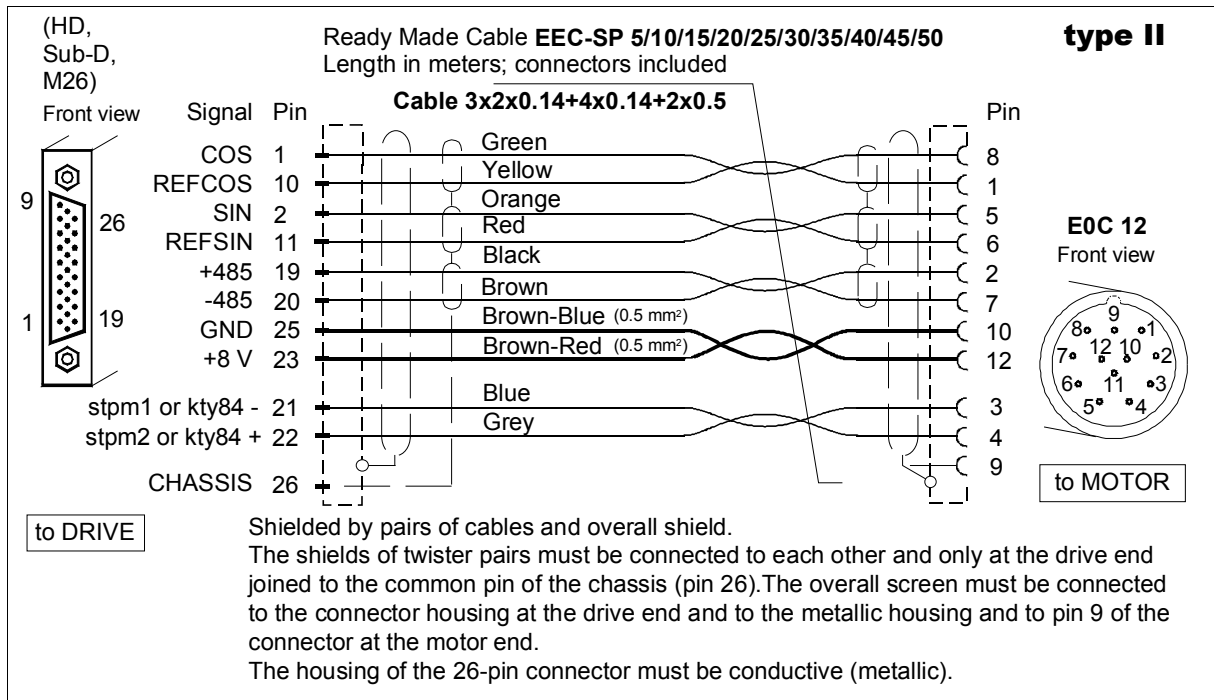

Codes of the sales reference of FAGOR cables

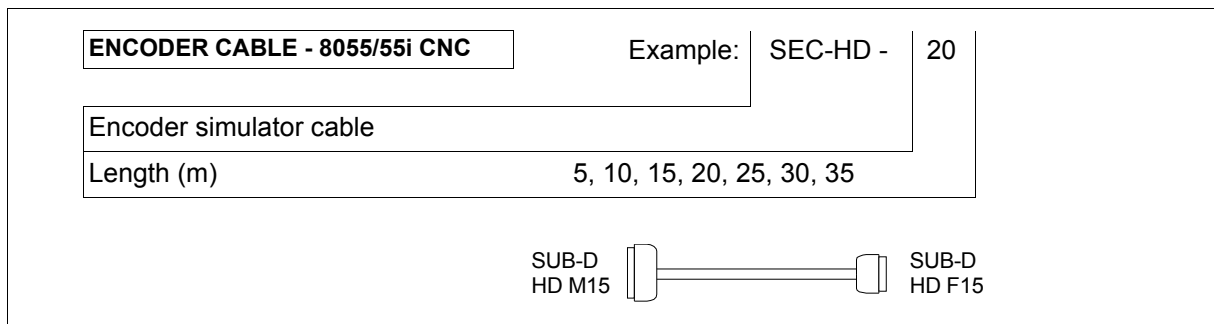
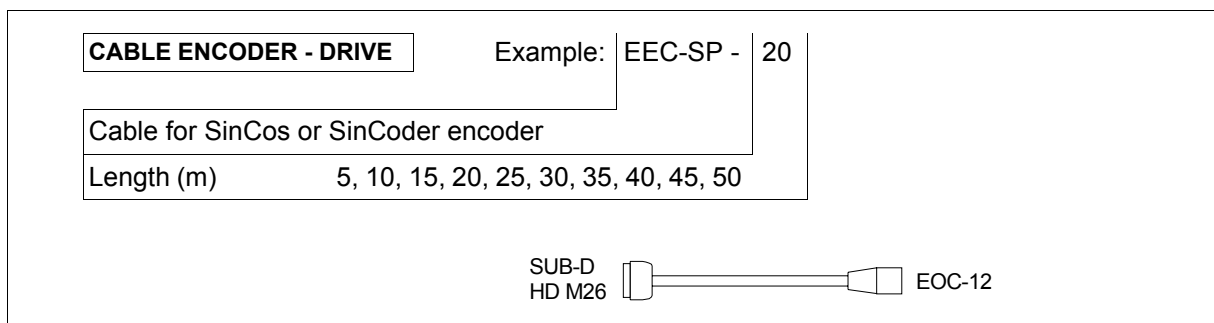
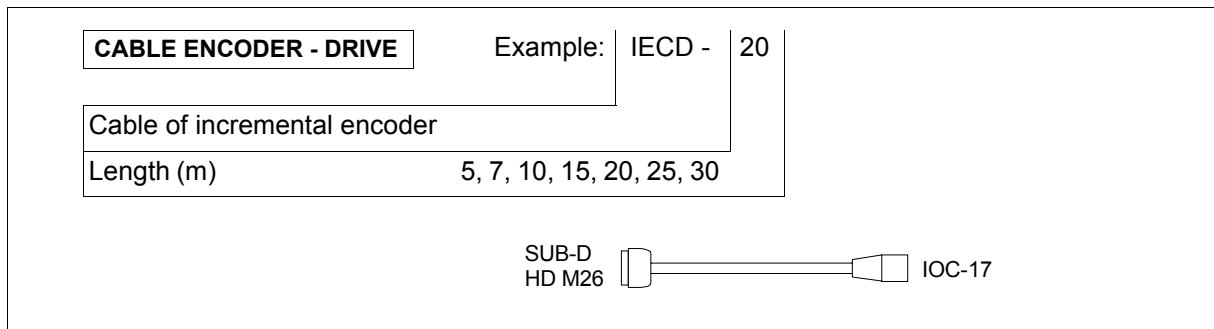

Analog command signal connection

The command governing the motor may be a velocity or current command. All the command signal lines must be shielded twisted pairs. The shield must be connected to the voltage reference at the module (pins 2, 4 and 10).

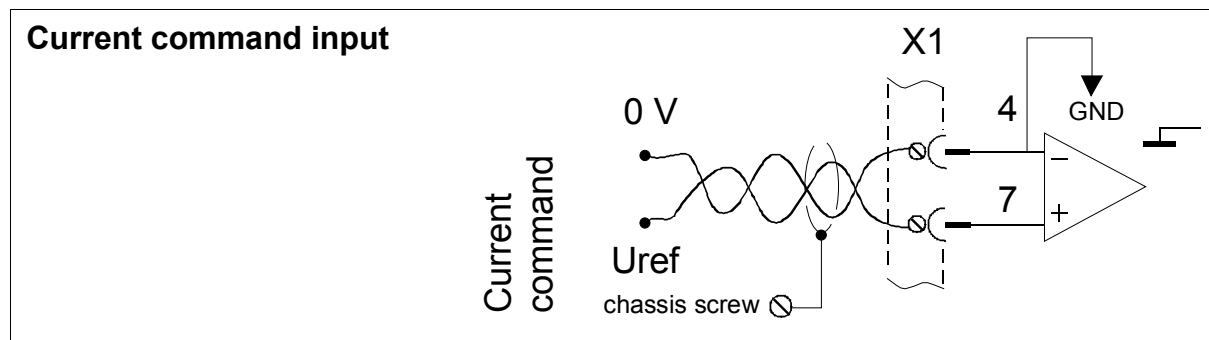

The input impedance of the velocity command is $56\text{ k}\Omega$ (a range $\pm 10\text{ V}$). The input impedance of the current command is $56\text{ k}\Omega$ (a range $\pm 10\text{ V}$).

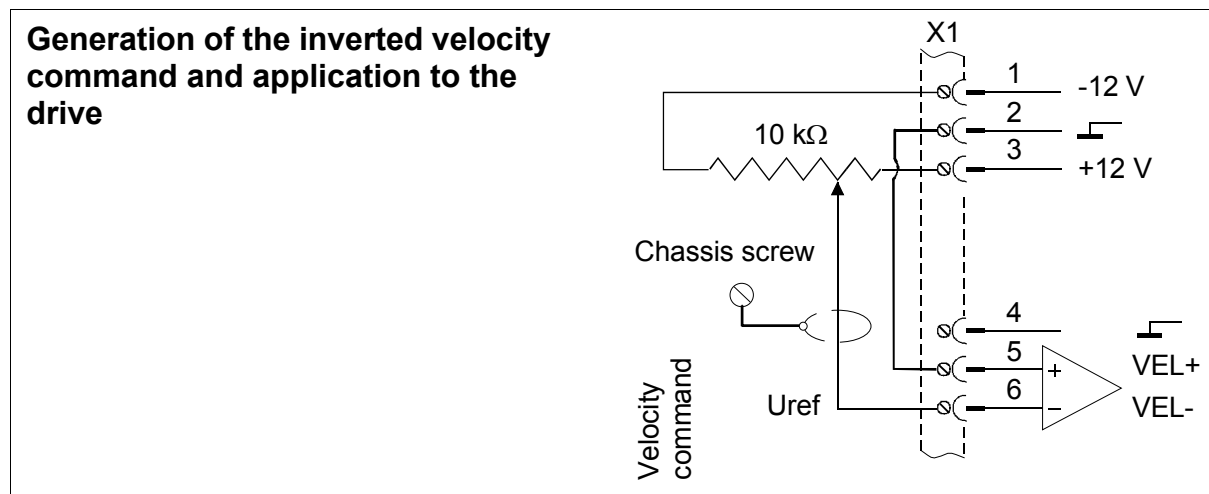
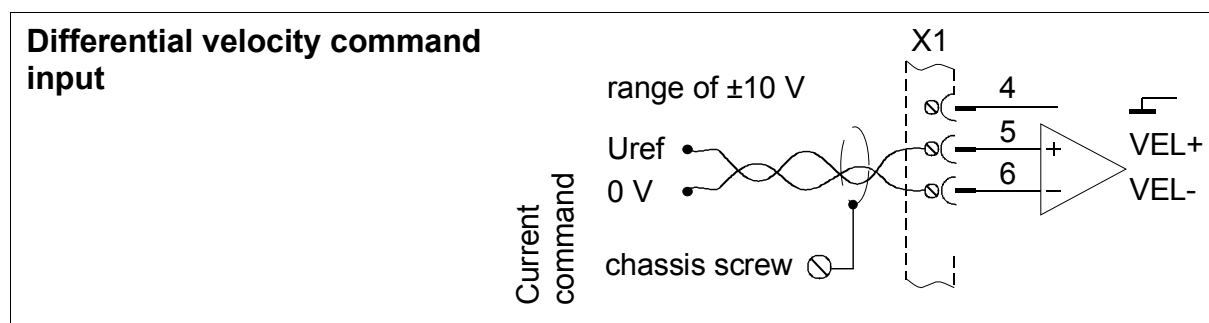

MCS-PC connection. RS-232 serial line

Connecting a PC compatible computer with an MCS drive via RS-232 makes it possible to set and monitor system variables facilitating its adjustment.

The motor table may be updated in the E²PROM through this line.

The connection cable is:

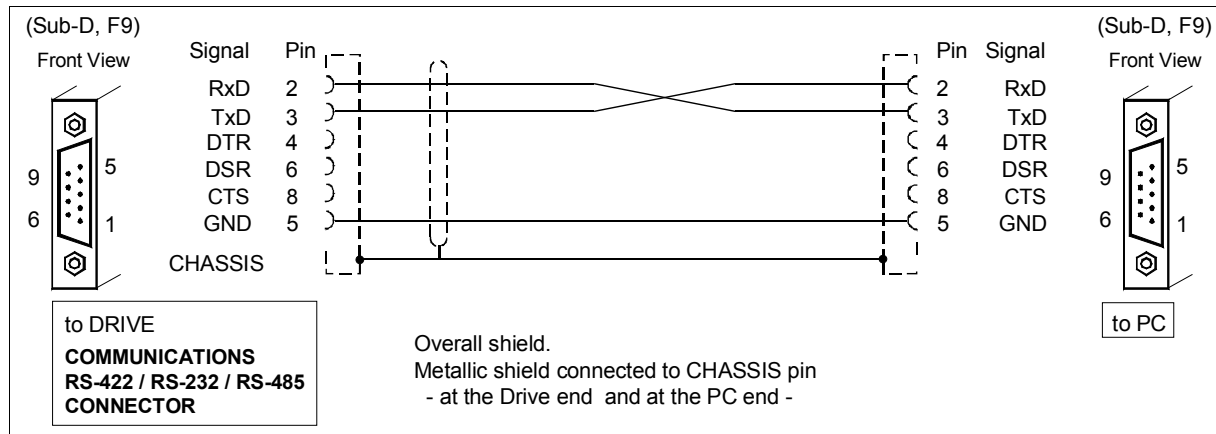

Diagram of the electrical cabinet

This is an orientative diagram for the installation of the electrical cabinet. This diagram may be modified according to the requirements of each application. It includes a simple circuit for the voltage supply of the brake of the servo motors.

NOTE. When installing an auto-transformer, the secondary must have a star connection and its middle point must be connected to GND.



MANDATORY: The use of fuses is a must.

Mains connection and maneuver diagram

The delayed disconnection of KA3 contacts is useful so:

- ❑ The Drive Enable stays active while the motor brakes at maximum torque.
- ❑ The brake holds the motor after it has stopped.

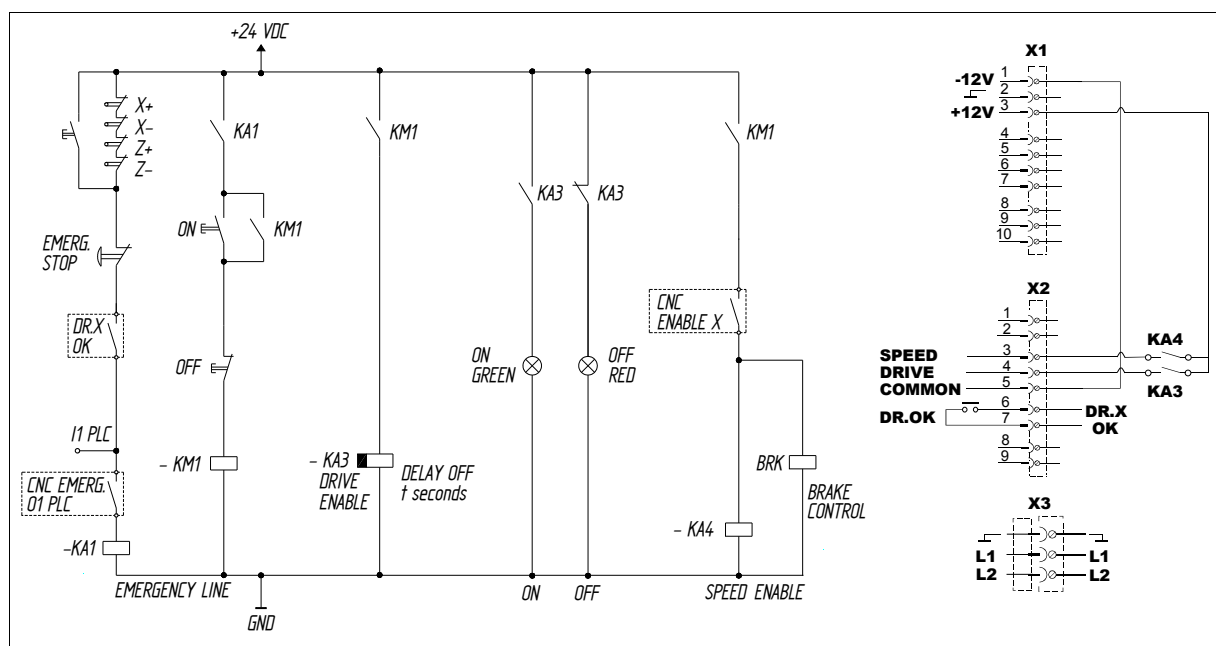

Initialization and adjustment

After starting the motor-drive system, the way the parameters, variables and commands will be displayed and edited will be determined by the access level: FAGOR level, user level or basic level restricting, depending on the level, the access to some or all of them.

This access level is determined by entering its corresponding code in the GV7 variable. This way, with no access level, the following variables may be displayed in this order:

- SV1: VelocityCommand
- SV2: VelocityFeedback
- CV3: CurrentFeedback

To access the rest, access GV7 and browse through as shown below:

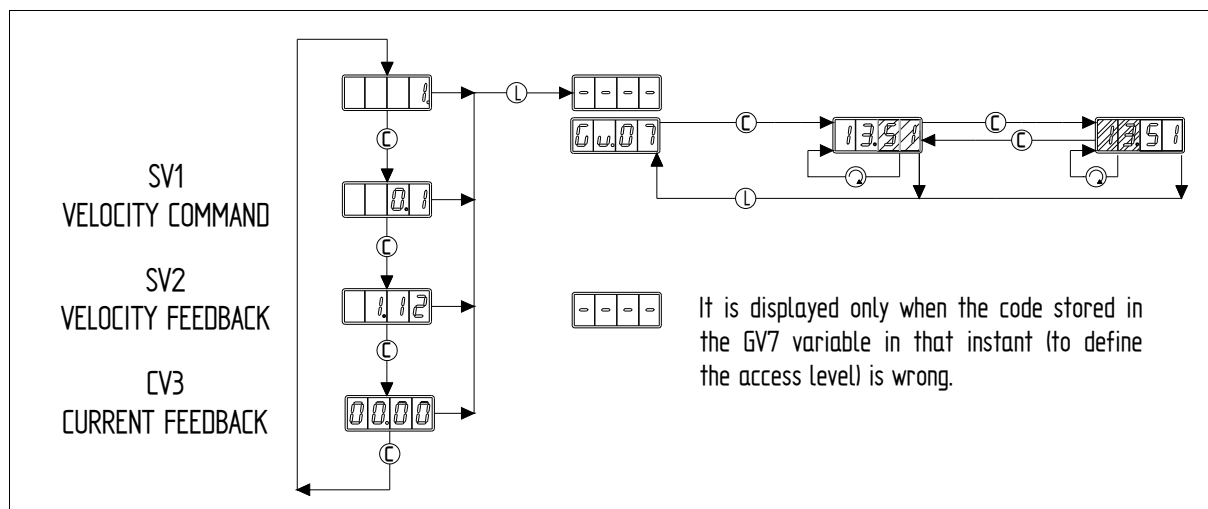

If the code is correct, all the parameters, variables and commands permitted by that level may be accessed by turning the rotary decoder. If it is not correct, it will display 4 horizontal lines and the GV7 again allowing to write the level code again.

If the system consist of an MCS drive with a motor having an **encoder with an incremental I0**, the drive must be told which type motor it must govern by means of parameter **MP1**. When connecting a motor that uses a SinCos or SinCoder encoder, this is not necessary because the encoder will “tell” the drive which type of motor it is mounted on.

Although it is less frequent, in the case of the sincoder, it is also possible that the sincoder does not inform the drive about the type of motor it is installed in; thus the MP1 parameter must be edited like encoder I0. To operate in this mode, the automatic initialization of the encoder must be disabled by setting parameter GP15=0.

Once the MP1 has been found by turning the decoder until it appears on the display, follow the sequences indicated in the section “**PARAMETERS, VARIABLES & COMMANDS**” in this manual.

Once the motor has been defined, it must be initialized with the GC10 variable in order to set the initial values for the drive that matches the selected motor. Once the GC10 has been found by turning the decoder until appears on the display.

The sequence to follow is shown below:

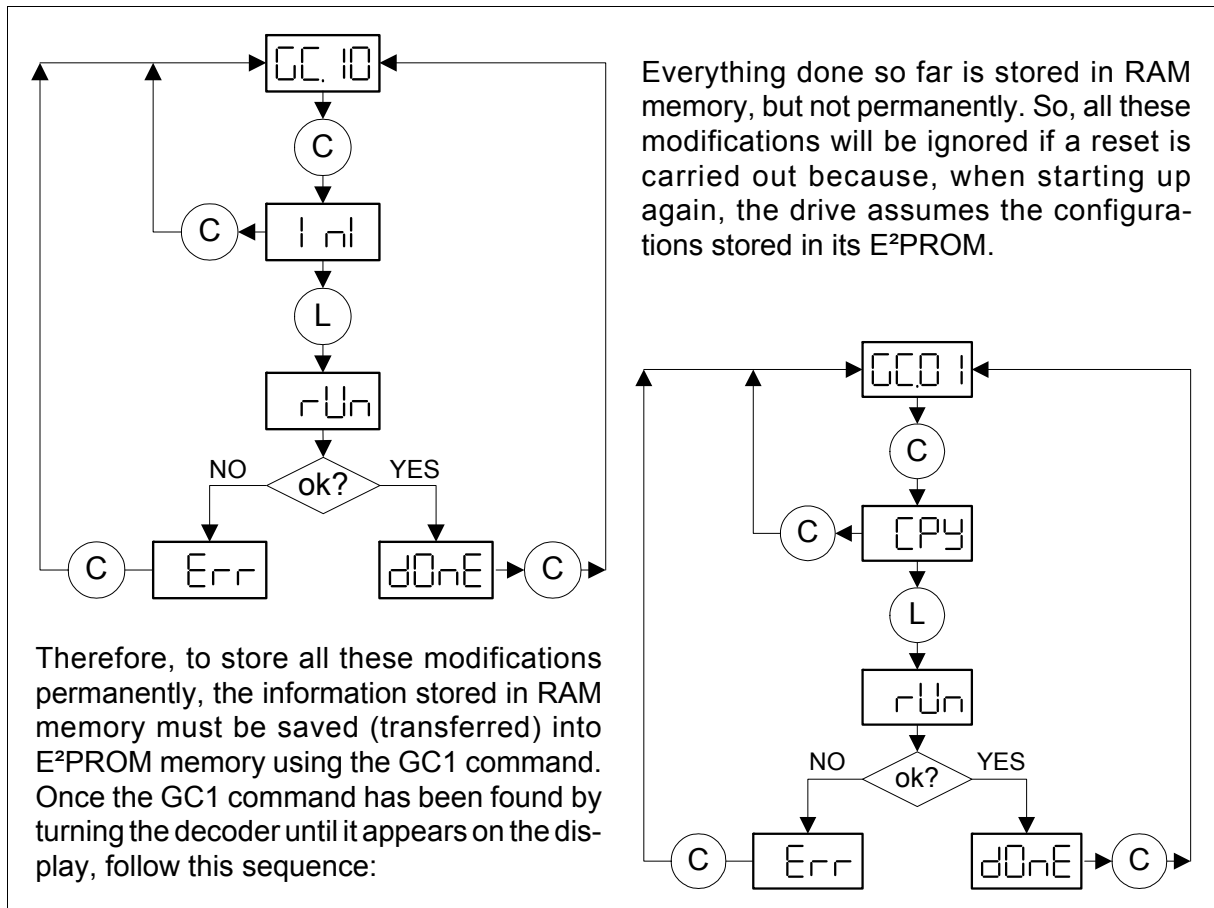

Besides these two commands whose sequences have been shown in the previous two figures, there are others that follow the same sequences but with the mnemonic of the functionality of the command itself. They may be displayed as shown here.

After finding the command, use a short push to display the function mnemonic of the command. A long push confirms its execution whereas a short push returns it to its initial state.

While executing the command, the display shows the word: **rUn** (it is not displayed in commands that are executed very fast).

If the command has been executed properly, the displays shows the word: **dOnE**. Otherwise, in case of an error, it displays the word: **Err**.

In any of these instances, a short push returns it to its initial state.

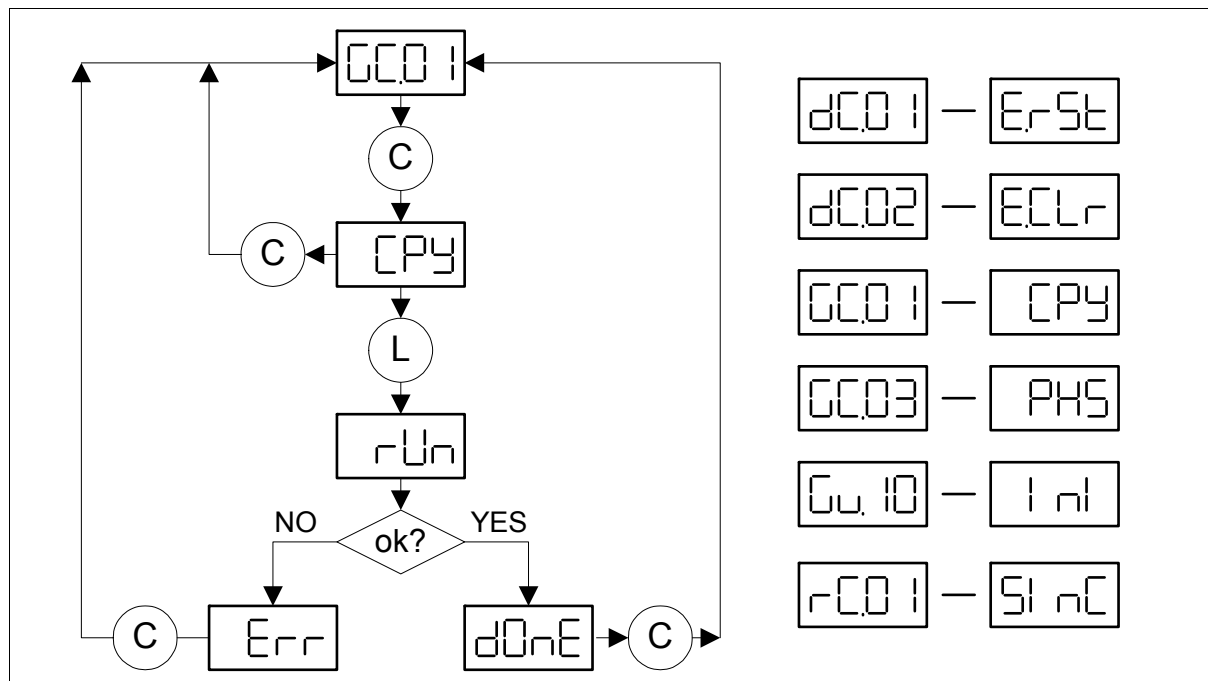

To obtain information on the type of drive (it can be read but not edited) coherent with the selected motor, find GV9 and follow the indication of the figure below to display the different fields that show their characteristics:

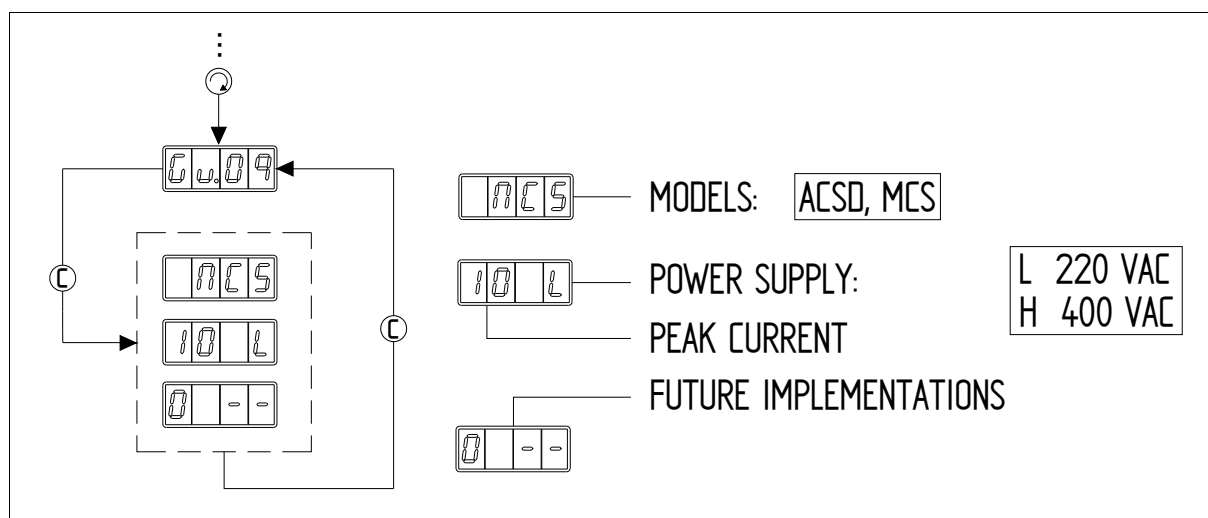

If for any reason, the access level must be changed, display the GV7 variable and write the new code. Then, display GC1 and apply the command as described earlier. Finish the procedure with a RESET.

On the other hand, when adjusting it, proceed as follows:

- Verify that desired velocity or current command is selected. To do this, make sure that all the parameters involved (such as SP45, WV4,...) are properly set.
- When using external analog command, verify that it is output to the proper pins.

When using analog command, set parameters SP20 and SP21 with the proper values in order to obtain the desired response to the velocity command entered.

- ❑ Use parameter CP20 to set the maximum peak current value of the drive to obtain the best dynamic response.
- ❑ Set the velocity PI gain using parameter SP1 (proportional gain K) and SP2 (integral K) until the desired system performance is obtained.
- ❑ Adjust the velocity offset using parameter SP30.
- ❑ Send a 0 V velocity command to the drive (jumping pins 4, 5 and 6 of connector X1).
- ❑ Measure the motor speed and adjust the offset using parameter SP30 until the motor stops. Be careful because this method only eliminates the offset of the drive. The CNC may have an offset of its own which must be adjusted at the CNC.

In order to adjust the offset for the whole control loop:

- ❑ Set the CNC in DRO mode keeping the Drive_Enable and Speed_Enable signals active.
- ❑ Change parameter SP30 until the motor stops.

Another method would consist in setting an axis position with the CNC and adjusting parameter SP30 until the following error (axis lag) is symmetrical.

WinDDSSetup

FAGOR application for PC. Establish communication between the MCS unit and the PC via serial port.

The operator can use the application's interface to read, modify, save to a PC file and download from a PC file all the parameters and variables of the drive and check the status of the motor-drive combination; thus making the final adjustment of the servo drive system easier, faster and more comfortable.

This also makes it easier to manufacture many machines that have MCS units.

NOTE. Only MCS units whose software version is 2.04 or greater can communicate with the WinDDSSetup installed on the PC. The version of the WinDDSSetup application must be 06.08 or greater.

PARAMETERS, VARIABLES & COMMANDS

Notation

< group > < type > < index > where:

Group. Identifying character of the logic group to which the parameter or variable belongs.

There are the following groups of parameters:

GROUPS OF PARAMETERS, VARIABLES & COMMANDS			
N°	FUNCTION	GROUP	LETTER
1	Control signals	Terminal box	B
2	Current control loop	Current	C
3	Error diagnosis	Diagnosis	D
4	Encoder simulator	Encoder	E
5	General of the system	General	G
6	System hardware	Hardware	H
7	Analog and digital inputs	Inputs	I
8	Temperatures and voltages	Monitoring	K
9	Motor properties	Motor	M
10	Analog and digital outputs	Outputs	O
11	System communication	RS232/422/485 Modbus	Q
12	Rotor sensor properties	Rotor	R
13	Velocity control loop	Velocity	S
14	Torque and power parameters	Torque	T
15	Internal function generator	Internal generator	W

Type. Character identifying de type of data which the information corresponds to. May be:

- Parameter (P) defining the system operation.
- Variable (V) that can be read and modified dynamically.
- Command (C) that carries out a specific action.

Index. Character identifying the parameter or the variable within the group to which it belongs.

Definition examples:

SP10: **S** group, **P** Parameter, Nr 10.

CV11: **C** group, **V** Variable, Nr 11.

GC1: **G** group, **C** Command, Nr 1.

Access level.

The access level is defined by the number following the ID: Thus:

- FAGOR level
- USER level
- BASIC level

Examples of access levels

SP10 **basic** : **S** group, Parameter **P**, Nr **10**, Access level (**BASIC**)

CV11 **FAGOR**, RO: **C** Group, **V** variable, Nr **11**, Access level (**FAGOR**), read-only variable (**RO**).

Modifiable variable.

Any modifiable variable, in other words, that can be read and written, will carry the (RW) label to identify it as such next to its access level. The (RO) label means that the variable is Read Only.

Note that all the parameters have the (RW), i.e. they can be read and written.

Example of a modifiable variable

DV32 FAGOR, **RW**: D Group, V Variable, Nr 32, (FAGOR) Access level, (**RW**) modifiable..

Groups

B. Non-programmable inputs-outputs

BV14 FAGOR, RO NotProgrammableIOs



Function

Indicates the logic values of the electrical control signals of the drive. 24 V at the electrical input mean a logic 1 at the bits of this variable.

Bit	Function
15, ..., 4	Reserved
3	Programmable input Pins 8-9 of terminal strip X2 Default value (IP14=4), error reset
2	Drive_OK output Pins 6-7 of terminal strip X2
1	Speed_Enable input Pin 3 of terminal strip X2
0	Drive_Enable input Pin 4 of terminal strip X2

C. Current

CP1 FAGOR, RW CurrentProportionalGain



Function

Value of the proportional action of the current PI.

Valid values

0 ... 999.

Default value

Depends on the motor-drive combination.

CP2 FAGOR, RW CurrentIntegralTime



Function

Value of the integral action of the current PI.

Valid values

0 ... 999.

Default value

Depends on the motor-drive combination.

CP10 USER, RW**VoltageAmpVolt****CP.10****Function**

Parameters CP10 and CP11 define the relationship between the voltage of the analog input IV2 and the current that this input generates in IV3.

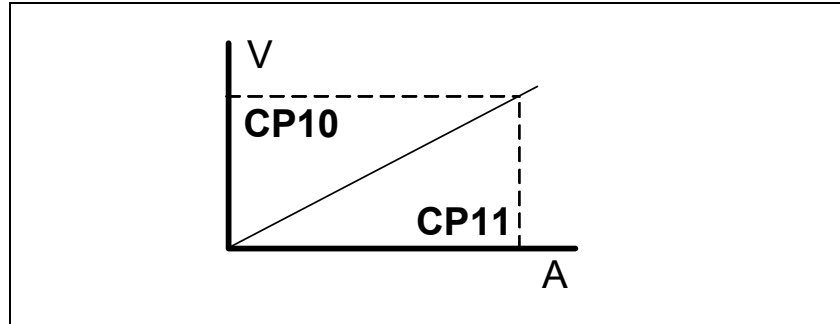
**Valid values**

1.000 ... 9.999 V.

Default value

9.500 V.

CP11 USER, RW**AmpAmpVolt****CP.11****Function**

See parameter CP10 .

Valid values

1.00 ... 50.00 A. Depends on the connected drive.

Default value

MP3. Rated motor current (in amperes).

CP20 BASIC, RW**CurrentLimit****CP.20****Function**

Limit of the current command that reaches the system's current loop.

Valid values

0.00 ... 50.00 Arms. CP20 must never exceed the smallest value given by the peak current of the motor (5xMP3) and of the drive.

Default value

CP20 takes the lowest value of the ones given by the motor and drive peak currents.

CP30 FAGOR, RW**CurrentCommandFilter1Type****CP.30****Function**

Parameter in charge of enabling/disabling the current filter.

Valid values

Value	Function
1	Enables the filter
0	Disables the filter (by default)

CP31 FAGOR, RW**CurrentCommandFilter1Frequency****CP.31**

Function Sets the natural frequency in Hz of a notch filter that acts upon the current command.

Valid values 0 ... 4 000.

Default value 0.

CP32 FAGOR, RW**CurrentCommandFilter1Damping****CP.32**

Function Sets the bandwidth in Hz of a notch filter that acts upon the current command.

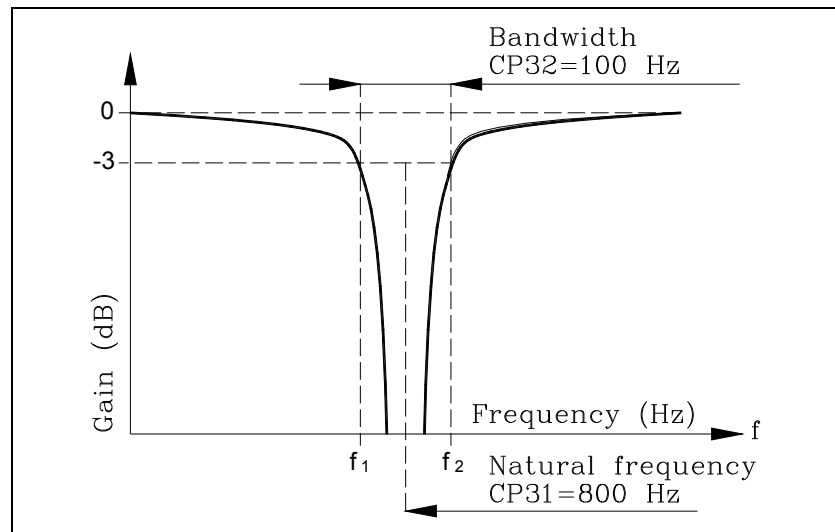

Valid values 0 (by default) ... 1 000.

CP45 USER, RW**CurrentCommandSelector****CP.45**

Function This parameter is used to determine the command source of the current loop.

Valid values 0 (by default), 1, 2 and 3.

Value	Function
0 by default	Normal operation. The current command comes from the velocity loop.
1	Function generator. Value of WV5 if the output of the function generator is applied to the current loop (WV4=2).
2	Digital. Value of CV15 that can be modified through the serial line.
3	External analog. It applies the value of the external auxiliary input (pins 4 & 7 of connector X1) after being treated, IV3, if IP17 has the right value (IP17=1).

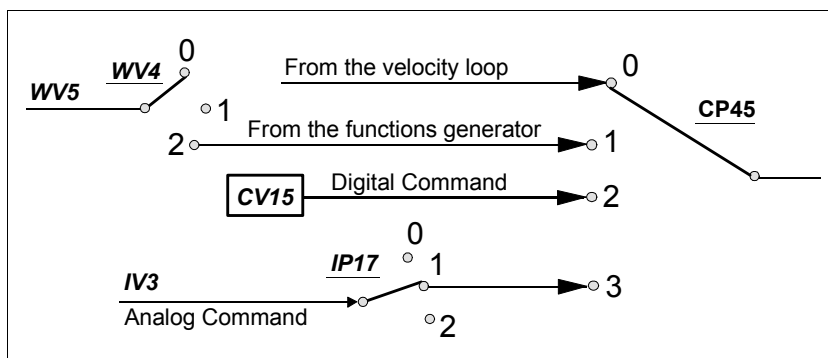

CV1	USER, RO	Current1Feedback	
------------	-----------------	-------------------------	--

Function Display the value of the feedback of the current going through phase V.

Valid values - 50 ... + 50 A (instant values).

CV2	USER, RO	Current2Feedback	
------------	-----------------	-------------------------	--

Function Display the value of the feedback of the current going through phase W.

Valid values - 50 ... + 50 A (instant values).

CV3	USER, RO	CurrentFeedback	
------------	-----------------	------------------------	--

Function Display the rms current circulating through the motor.

Valid values 0 ... 50 Arms (rms values).

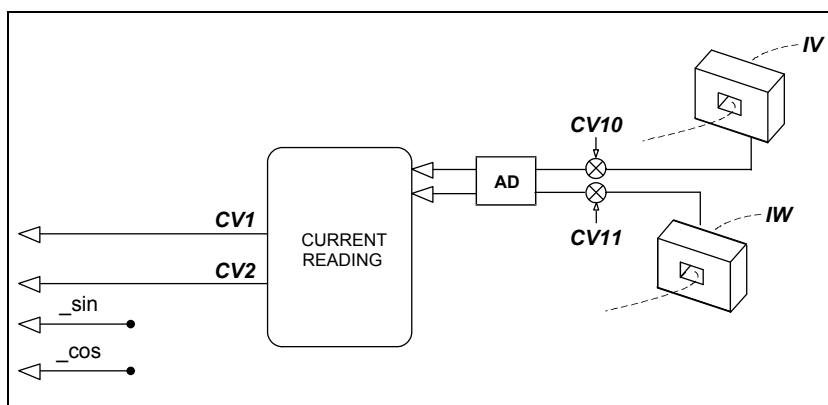

CV10	FAGOR, RO	Current1Offset	
-------------	------------------	-----------------------	--

Function Value of the automatic compensation of the current feedback offset of phase V.

Valid values - 2 000 ... + 2 000 mA (depends on the connected drive).

CV11 FAGOR, RO

Current2Offset



Function

Value of the automatic compensation of the current feedback offset of phase W.

Valid values

- 2 000 ... + 2 000 mA (depends on the connected drive).

CV15 USER, RW

DigitalCurrentCommand



Function

This variable registers the value of the digital current command.

Valid values

- 50.00 ... + 50.00 Arms.

D. Diagnosis

DV17 USER, RO

HistoricOfErrors



Function

5-word register containing the numbers of the last 5 errors occurred in the drive module.

The programming module can display each one of these 5 errors one by one using short pushes from the most recent to the oldest.

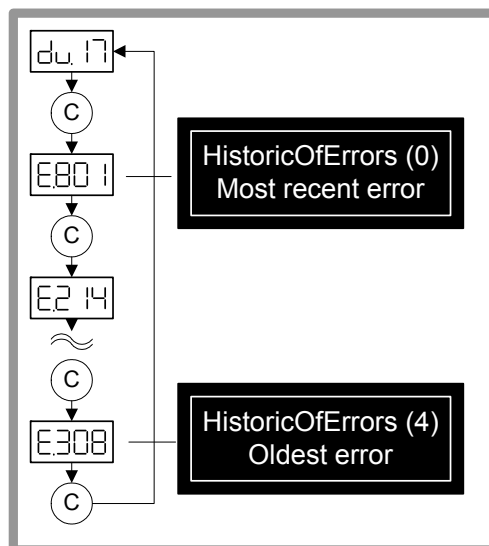

Valid values

All the possible error codes implemented in the loaded software version. Code 0 means no error.

DV31 FAGOR, RO**DriveStatusWord****Function**

The DV31 variable contains a numerical data coded into 16 binary bits and represents the system status as shown by the attached table. Bits (from the most to the least significant).

Bit	Function
15, 14	Power & Torque Status. (0,0) DoingInternalTest (DRVSTS_INITIALIZING) (0,1) ReadyForPower (DRVSTS_LBUS) (1,0) PowerOn (DRSTS_POWER_ON) (1,1) TorqueOn (DRSTS_TORQUE_ON)
13	Error bit
12	Warning
11	OperationStatusChangeBit
10 ... 7	Reserved
6	ReferenceMarkerPulseRegistered
5	ChangeCommandsBit
4 ... 1	Reserved
0	DriveStatusWordToggleBit

DV32 FAGOR, RW**MasterControlWord****Function**

The DV32 variable contains a numerical data coded into 16 binary bits and represents the control signals that act upon the drive through the serial line.

Bit	Function
15	Speed Enable
14	Drive Enable
13 ... 7	Reserved
6	Homing Enable
5 ... 1	Reserved
0	MasterControlWordToggleBit

DC1 USER, RW**ResetClassDiagnostics****Function**

Reset of the unit's errors. When an error occurs, this command may be used to reset it and restart the unit by first updating the error bit of DV31, DriveStatusWord, and then setting the drive in the ReadyForPower state. Note its difference with the unit's reset because the action carried out by this command keeps the RAM memory intact and therefore the parameter settings of the unit.

DC2 USER, RW**ResetHistoricOfErrors****Function**

Reset of the DV17 variable HistoricOfErrors (array). This command sets it to 0.

E. Encoder simulator**EP1 BASIC, RW****EncoderSimulatorPulsesPerTurn****Function**

Number of pulses generated by the encoder simulator per rotor revolution. If the encoder is ref. I0 (2500 ppt), the parameter value of the encoder simulator output is set in 5 ppt increments and in 2 ppt increments if it is ref. E1, E3 or A0. Note that the unit can limit the bandwidth of the simulator output. Hence, if the encoder is:

- I0 (2500 ppt), it is not limited.
- SinCos and the it is a 3000 motor or less, it is not limited.
- SinCos and the it is a motor of more than 3000 motor, it is limited to 2048 output pulses.

Valid values

0 ... 4096.

Default value

Number of pulses of the selected feedback device.

EP3 BASIC, RW**EncoderSimulatorDirection****Function**

Selection of the turning direction of the simulated encoder.

Valid values

0/1 Clockwise (by default) / Counterclockwise.

EP4 BASIC, RW**EncoderSimulatorHighFreqEnable****Function**

Bandwidth limitation of the pulse simulator output. It only has an effect with SinCos type motor feedback. See parameter EP1.

Valid values

0/1 Activate/Desactivate.

Default value

0 Limitation activated. The high frequency of the encoder simulator output is not enabled.

G. General

GP3	BASIC, RW	StoppingTimeout	
------------	------------------	------------------------	---

Function After deactivating the Speed_Enable and after the GP3 time has elapsed, if the motor has not stopped, it cancels the torque automatically and issues error E.004. If the motor stops within the GP3 time, it also cancels the torque but does not issue an error. To make this time infinite (never generating error E.004), set this parameter to "0".

Valid values 1 ... 9 999 ms, 0 (infinite).

Default value 500 ms.

GP5	BASIC, RO	ParameterVersion	
------------	------------------	-------------------------	---

Function This parameter represents the version of the parameter table that has been loaded at the drive.

GP9	BASIC, RW	DriveOffDelayTime	
------------	------------------	--------------------------	--

Function After the motor has stopped because the Speed_Enable function has been disabled, the cancellation of the the Drive_Enable function (that implies PWM-OFF) is delayed by a time period indicated by GP9. It is useful on axes not compensated with a holding brake. To make this time period infinite, set it to 0 and to remove it, set it to 1.

Valid values 1... 9999 ms, 0 (infinite).

Default value 50 ms.

GP11	USER, RW	IOFunctionsTime	
-------------	-----------------	------------------------	---

Function Value of the time used in functions OutFunc1 & OutFunc2.

Valid values 0 ... 9 999 ms.

Default value 2 000 ms.

GP15	FAGOR, RW	AutomaticInitialization	
-------------	------------------	--------------------------------	---

Function When having a SinCos or SinCoder encoder, it enables reading MP1 directly from the sensor and consequently loading certain drive parameter automatically. See section "**Initialization and adjustment**" in this manual.

If GP15 = 0, it does not check the format of MP1.

Valid values 0 Disabled.
 1 Enabled (by default).

GP16 BASIC, RW	MonoPhaseSelector	
------------------------------	--------------------------	---

Function Drives MCS-5L (220 V) and MCS-10L (220 V) can work with single-phase power voltage without launching the “phase missing” warning. This parameter has no effect on the rest of the units.

Valid values 0 Disabled (by default).
 1 Enabled.

GV2 BASIC, RO	ManufacturerVersion	
-----------------------------	----------------------------	---

Function Displays the software version in use.

GV5 BASIC, RO	CodeChecksum	
-----------------------------	---------------------	---

Function It registers the checksum value of the software version loaded at the drive.

Valid values - 32 768 ... 32 767 (although the programming module can only display the 4 least significant digits). E.g.: If GV5=27 234, the display of the programming module shows 7234.

GV7 BASIC, RW	Password	
-----------------------------	-----------------	---

Function Variable where the password is entered to change the access level. The system will change the access level corresponding to the password entered.

Valid values 0 ... 9 999.

GV9 BASIC, RO	DriveType	
-----------------------------	------------------	---

Function This variable informs of the drive's sales reference. See section “**Initialization and adjustment**” in this manual.

GV11 BASIC, RW	SoftReset	
------------------------------	------------------	---

Function Variable that resets the unit by software.

Valid values 0 and 1 (with 1, it resets the unit).

GV16	USER, RO	MotorTableVersion	
-------------	-----------------	--------------------------	---

Function Version of the motor table.

GV75	FAGOR, RO	ErrorList	
-------------	------------------	------------------	---

Function List of the error numbers active in the unit.

Valid values 0 ... 999.

GC1	BASIC, RW	BackupWorkingMemoryCommand	
------------	------------------	-----------------------------------	---

Function Command to execute the parameter transfer from RAM to E²PROM.

GC3	FAGOR, RW	AutophasingCommand	
------------	------------------	---------------------------	---

Function Command that lets activate the autophasing sequence.

Procedure to follow:

- Connect the drive to the motor with the SinCos or Sin-Coder encoder installed (power and feedback cables) and without a load on the shaft.
- Apply control voltage and power.
- Activate the Drive Enable input of the drive (pin 4 of X2).
- Select GC3 and do a short push at the selector of the programming module. The display will show TUNN.
- Do a long push. The display will show RUN. Note that if the drive is not enabled, it will display ERR, do a short push to get out of this situation.

The motor will start positioning and after about 30 or 40 seconds the display shows DONE (do a short push to get out). At this instant, the new Rho has been calculated. Its value may be displayed in the RV3 variable.

- Select MP1 and edit the motor type.
- Select RC1 and execute it to save the new values of RV3 and MP1 in the E²PROM of the encoder.

GC10	BASIC, RW	LoadDefaultsCommand	
-------------	------------------	----------------------------	---

Function Command to initialize parameters. This command loads the default parameters of the drive for the motor whose ID is stored in parameter MP1. See section “**Initialization and adjustment**” in this manual.

H. Hardware

HV5 BASIC, RO PLDVersion

H.05

Function Software version installed in the unit's PLD's.

I. Inputs

IP6 USER, RW DigitalInputPolarity

I P.06

Function Sets the polarity (inverted or not inverted) of the programmable input (pins 8 and 9 of X2).

Valid values 0/1 Not inverted / Inverted.

Default value 0 Not inverted.

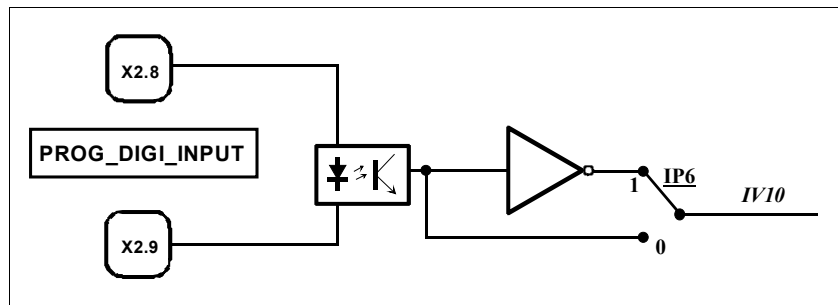

IP14 USER, RW DigitalInputFunctionSelector

I P.14

Function Determines the function assigned to the digital input of the unit. The programmable digital input (pins 8 and 9 of X2) is configured as remote input for resetting errors (IP=04).

Valid values 0 ... 4.

Value	Function	Description
0	Missing	
1	InFunc1	Reset of the integral action of the velocity loop
2	InFunc2	Invert the velocity command
3	InFunc3	Halt function (drive management)
4	InFunc4	Error reset (ResetClassDiagnostics, DC1=3)

Default value 4 Error RESET.

IP17	USER, RW	AnalogFunctionSelector	
-------------	-----------------	-------------------------------	---

Function Determines the analog function assigned to the programmable analog input.

Valid values 0 ... 2.

Default value 0.

IV3 as input
to function Nr ▶▶▶

IP17	Function
00	Not used
01	Func1
02	Func2

IV1	BASIC, RO	AnalogInput1	
------------	------------------	---------------------	---

Function Monitors the input voltage through analog input 1 (pins 5-6 of X1). It's display is in volts.

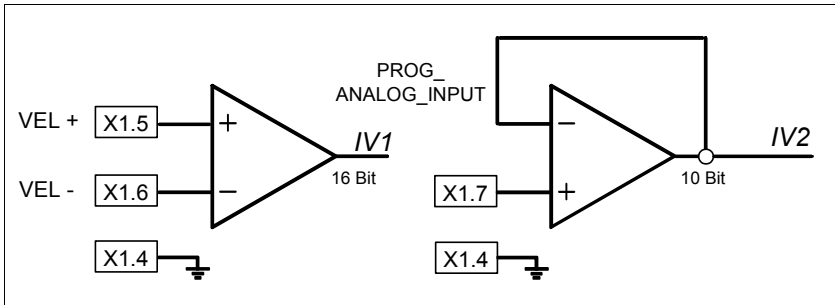

IV2	USER, RO	AnalogInput2	
------------	-----------------	---------------------	---

Function Monitors the input voltage through analog input 2 (pin 7 of X1). It's display is in volts.

IV3	USER, RO	CurrentCommandAfterScaling	
------------	-----------------	-----------------------------------	---

Function Contains the value of the auxiliary analog command (pin 7 of X1; usually current command) after being affected by CP10 and CP11. It must never exceed the value of the maximum current of the unit.

Valid values - 50.00 ... + 50.00 Arms.

IV10	USER, RO	DigitalInputs	
-------------	-----------------	----------------------	---

Function This variable reflects the status of the programmable digital input at pins 8-9 of connector X2. The status of this variable is affected by IP6.

Valid values 0 (by default) and 1.

K. Monitoring

KP3	USER, RW	ExtBallastPower	
------------	-----------------	------------------------	---

Function Contains the value of power of the external ballast resistor.
Valid values 200 ... 2 000 W.
Default 200 W.

KP4	USER, RW	ExtBallastEnergyPulse	
------------	-----------------	------------------------------	---

Function Contains the value of the energy pulse that can be dissipated by the external ballast resistor.
Valid values 200 ... 2 000 J.
Default value 200 J.

KV6	BASIC, RO	MotorTemperature	
------------	------------------	-------------------------	---

Function Motor temperature in degrees centigrade. For the time being, it is now only valid for the FKM family.
Valid values -20 ... 200 °C.

KV10	USER, RO	CoolingTemperature	
-------------	-----------------	---------------------------	---

Function It displays the temperature of the heatsink of the power stage.
Valid values 0 ... 200 °C.

KV32	USER, RO	I²tDrive	
-------------	-----------------	----------------------------	---

Function Variable internally useful to the system. It measures the internal load level of the calculation of the i²t at the drive in percentage used over the maximum.
Valid values 0 (by default) ... 100 %.

KV36	USER, RO	I²tMotor	
-------------	-----------------	----------------------------	---

Function Variable internally useful to the system. It measures the internal load level of the calculation of the i²t at the motor in percentage used over the maximum.
Valid values 0 (by default) ... 100 %.

KV40	USER, RO	IntBallastOverload	
-------------	-----------------	---------------------------	---

Function Shows the load percentage on the ballast resistor in a drive. Useful for the i²t protection of the resistor. A value greater than 100 % in this variable causes error E.314.

Valid values 0 (by default) ... 100 %.

KV41	USER, RW	BallastSelect	
-------------	-----------------	----------------------	---

Function Selector that determines whether the ballast resistor is external or internal.

Valid values 0/1 External/Internal (by default).

M. Motor

MP1	BASIC, RW	MotorType	
------------	------------------	------------------	--

Function Motor identification. The limits of certain parameters depend on the value of MP1 (e.g.: the upper limit of SP10 is 110 % of the motor rated speed) like its default parameter initialization through GC10. See command GC10. To govern a non-FAGOR motor, insert the NULL value in the first field of MP1.

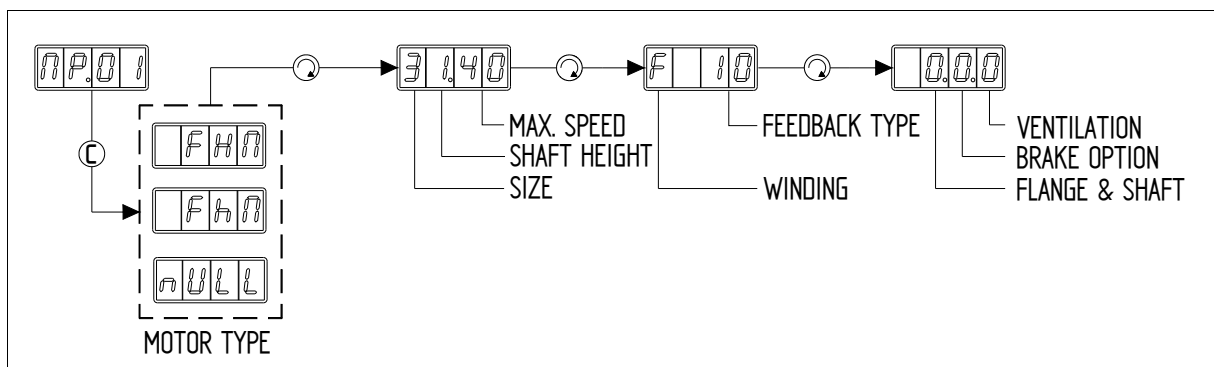

MP2	FAGOR, RW	MotorTorqueConstant	
------------	------------------	----------------------------	---

Function Contains the torque constant of the synchronous motor, (motor torque according to the rms current).

Valid values 0.0 ... 10.0 N·m/Arms.

Default value It depends on the motor connected (N·m/Arms).

MP3 FAGOR, RW MotorContinuousStallCurrent

MP03

Function Contains the motor rated current. Manipulating MP3 may affect parameter CP20 directly. See parameter CP20.
Valid values 0.00 ... 50.00 Arms. Depends on the motor connected.
Default value It depends on the motor connected (Arms).

O. Analog and digital outputs

OP1 USER, RW DA1IDN

OP01

OP2 USER, RW DA2IDN

OP02

Function They identify the internal analog variables of the drive that will be reflected at the electrical outputs and will be affected by the OP3 and OP4 gains respectively. Channel 1 (pin 8 of X1) and channel 2 (pin 9 of X1).

Valid values Name of any parameter or variable of the table.

Default value 04 for OP1 and 07 for OP2.

OP1	variable	Name	OP2	variable	Units
00	SV15	DigitalVelocityCommand	00	SV15	rev/min
01	SV1	VelocityCommand	01	SV1	
02	SV6	VelocityCommandAfterFilters	02	SV6	
03	SV7	VelocityCommandFinal	03	SV7	
04	SV2	VelocityFeedback	04	SV2	dN·m
05	TV1	TorqueCommand	05	TV1	
06	TV2	TorqueFeedback	06	TV2	cA
07	CV3	CurrentFeedback	07	CV3	
08	WV5	GeneratorOutput	08	WV5	-
09	IV1	AnalogInput1	09	IV1	mV
10	IV2	AnalogInput2	10	IV2	
11	RV1	FeedbackSine	11	RV1	bits
12	RV2	FeedbackCosine	12	RV2	

OP3	USER, RW	DA1ValuePer10Volt	OP.03
------------	-----------------	--------------------------	--------------

OP4	USER, RW	DA2ValuePer10Volt	OP.04
------------	-----------------	--------------------------	--------------

Function They define the gain of channel 1 (pin 8 of X1) and channel 2 (pin of X1). There are 10 V at these outputs when the selected variable reaches this value.

Units The units of the variable being displayed.

Valid values 0 ... 9 999.

Default value 4 000 and 3 000, respectively.

Example If OP1=04 → SV2, VelocityFeedback, in rpm (see previous table) and OP3=3 000.
It means that when the value of SV2 is 3 000 rev/min the analog output will be 10 V and it maintains this rpm/V ratio throughout its full range ± 10 V.

OP6	USER, RW	DigitalOutputPolarity	OP.06
------------	-----------------	------------------------------	--------------

Function Sets the polarity (inverted or not inverted) of the programmable digital input (pins 1 and 2 of X2).

Valid values 0/1 Not inverted (by default) / Inverted.

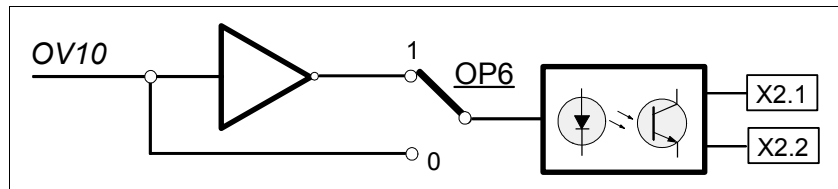

OP14	USER, RW	DigitalOutputFunctionSelector	OP.14
-------------	-----------------	--------------------------------------	--------------

Function They determine the activation of the various outputs of the digital functions available.

OP14	Function
00	Not used
01	OutFunc1
02	OutFunc2
03	OutFunc3
04	OutFunc4
05	OutFunc5
06	OutFunc6
07	OutFunc7

◀◀◀ **OV10** as output from function Nr

OP15 USER, RW

DigitalOutputWarningSelector

OP. 15

Function

Selector of the warning that will be displayed by the programmable output when function OutFunc7 is selected.

Valid values

- 0 I²t motor (by default)
- 1 I²t ballast.
- 2 I²t drive.

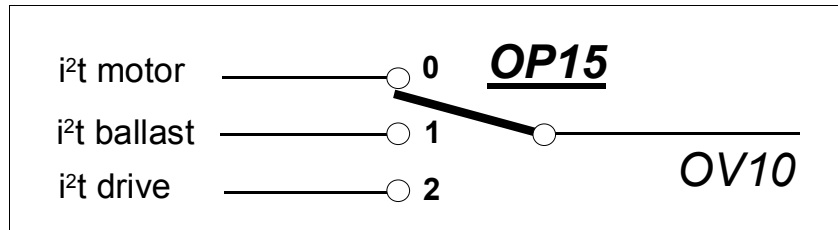

OV10 USER, RO

DigitalOutputs

OV. 10

Function

The OV10 variable contains the value of the output status of the various functions that may be selected with OP14.

Valid values

0 (by default) and 1.

Q. Communication

QP14 USER, RW

ProtocolTypeSelector

QP. 14

Function

Determines which hardware communication mode has been established (RS-232, RS-485, RS-422) with ModBus communication protocol and it is established through the serial COMMUNICATIONS line connector.

Valid values

0 ... 7.

Value	MODBUS
0, 1, 2	(RTU) & RS232
3	(RTU) & RS485
4	(RTU) & RS422
5	(ASCII) & RS232
6	(ASCII) & RS485
7	(ASCII) & RS422

Default value

0 (RTU) & RS232.

Function

Determines the communications parameters of the UART (Universal Asynchronous Receiver/Transmitter) of the serial line: baudrate, parity, Nr of bits, Nr of stop bits.

Bit	Function
15 ... 12	Reserved
11, 10	Stops bits 1 Stop bits 2 Stop bits
9 ... 6	Data bits 7 Data bits 8 Data bits
5, 4	Parity bits 0 no parity 1 even parity 2 even parity
3 ... 0	Communication speed (baudrate) 0 2400 Bd 4 9600 Bd 1 3600 Bd 5 19200 Bd 2 4800 Bd 6 38400 Bd 3 7200 Bd

Default value

1540 (9600, no parity, 8 data bits, 1 stop bit).

To edit this parameter, the programming module has a submenu like the one in the figure:

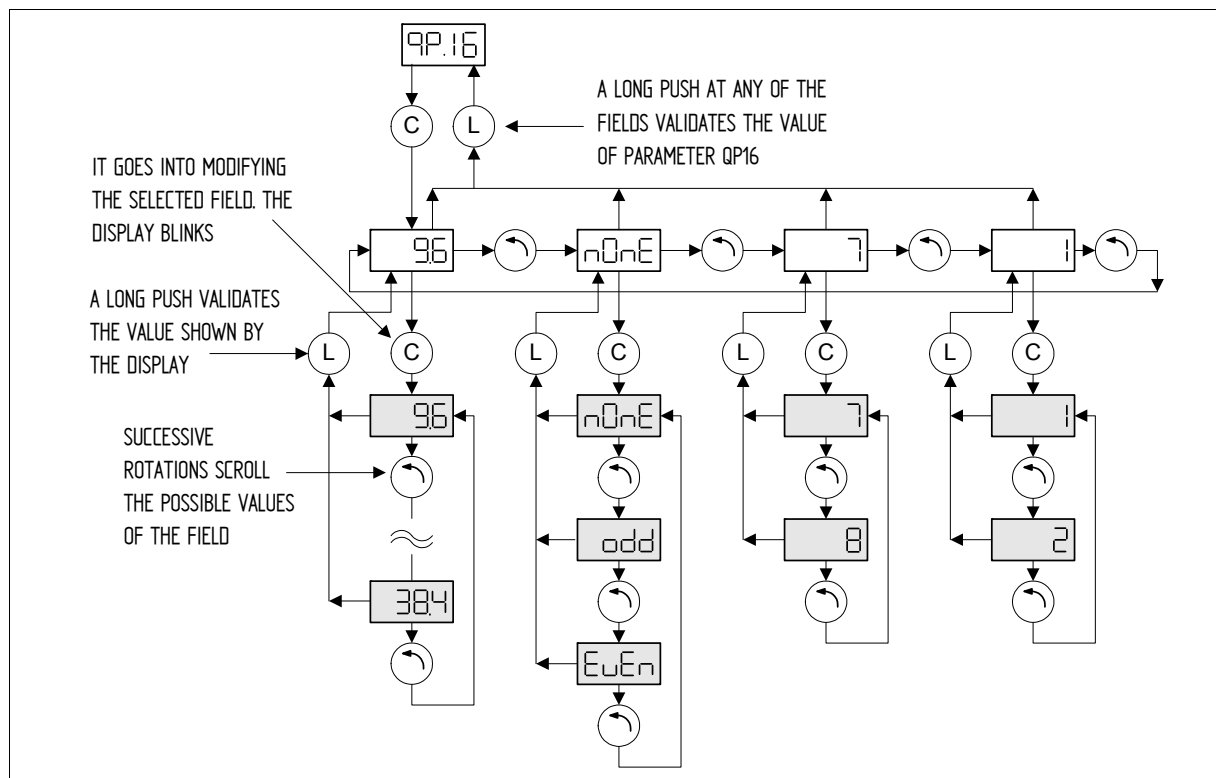

QV22	FAGOR, RO	IDNListOfInvalidOperationData	
-------------	------------------	--------------------------------------	---

Function Variable containing the parameters that are readjusted by the drive when it issues the error E.502 (incompatible parameters). The parameters are listed by their bus identifier (the WinDDSSetup shows the parameter names directly).

Valid values Any parameter bus identifier.

QV96	USER, RW	SlaveArrangement	
-------------	-----------------	-------------------------	---

Function This variable contains the number of the node assigned to the drive for communication.

Valid values 0 ... 127.

Value	ModBus protocol
0	Number Nr 0 (not commonly used)
1 ... 127	Node Nr assigned to the unit in a bus type communication.

R. Rotor sensor

RP1	FAGOR, RW	FeedbackSineGain	
------------	------------------	-------------------------	---

RP2	FAGOR, RW	FeedbackCosineGain	
------------	------------------	---------------------------	---

Function Compensation (proportional gain mode) of the amplitude of the sine/cosine signal that goes from the motor feedback to the drive. Entering 4 096 is the same as multiplying by 1. To assign a gain of 1.5 to the sine signal, set RP1 to 6 144 (= 4 096x1.5).

Valid values 0 (0 %) ... 8 192 (200 %).

Default value 4 096 (100 %).

RP3	FAGOR, RW	FeedbackSineOffset	
------------	------------------	---------------------------	---

RP4	FAGOR, RW	FeedbackCosineOffset	
------------	------------------	-----------------------------	---

Function Compensation (offset mode) of the sine/cosine signal that goes from the motor feedback to the drive.

Valid values - 2 000 ... 2 000.

Default value 0.

RP20	USER, RW	StegmanABLevelSense	
-------------	-----------------	----------------------------	---

Function Feedback failure protection sensitivity adjustment.
See "E.605" error code.

Valid values 30 ... 100 %.

Default value 100 %.

RV1	USER, RO	FeedbackSine	
------------	-----------------	---------------------	---

RV2	USER, RO	FeedbackCosine	
------------	-----------------	-----------------------	---

Function Sine and cosine of the feedback that goes from the motor to the drive as internal system variables.

Valid values - 512 ... 511.

RV3	FAGOR, RO	FeedbackRhoCorrection	
------------	------------------	------------------------------	---

Function Corrects the phase shift between the encoder shaft and the motor shaft. The motors are factory set and the value of this variable is stored in the encoder memory.

Valid values 0 ... 65 535 although the programming module can only display the 4 most significant digits. E.g. If RV3=27 500, the display of the programming module shows 2 750.

RC1	FAGOR, RW	EncoderParameterStoreCommand	
------------	------------------	-------------------------------------	---

Function Command that could be used to store the content of MP1 and RV3 in the E²PROM of the SinCos or SinCoder encoder.

S. Velocity

SP1	BASIC, RW	VelocityProportionalGain	SP.01
------------	------------------	---------------------------------	--------------

SP2	BASIC, RW	VelocityIntegralGain	SP.02
------------	------------------	-----------------------------	--------------

Function Value of the proportional / integral action of the velocity PI.

Valid values SP1: 0 ... 999.9 mArms/(rev/min).
SP2: 0.1 ... 999.9 ms.

Default value Depends on the motor-drive combination.

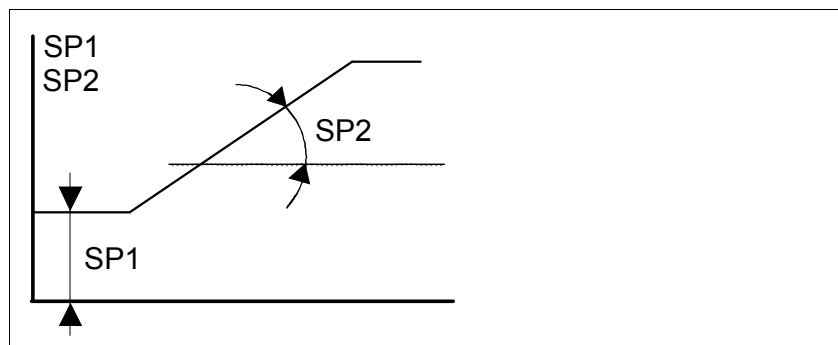

SP3	BASIC, RW	VelocityDerivativeGain	SP.03
------------	------------------	-------------------------------	--------------

Function Value of the derivative action of the velocity PI.

Valid values SP3: 0 (by default) ... 9 999.

SP10	BASIC, RW	VelocityLimit	SP.10
-------------	------------------	----------------------	--------------

Function Maximum velocity limit for SV7 (VelocityCommandFinal).

Valid values 0 ... 110 % of the motor rated speed in rev/min.

Default value 1 000 rev/min.

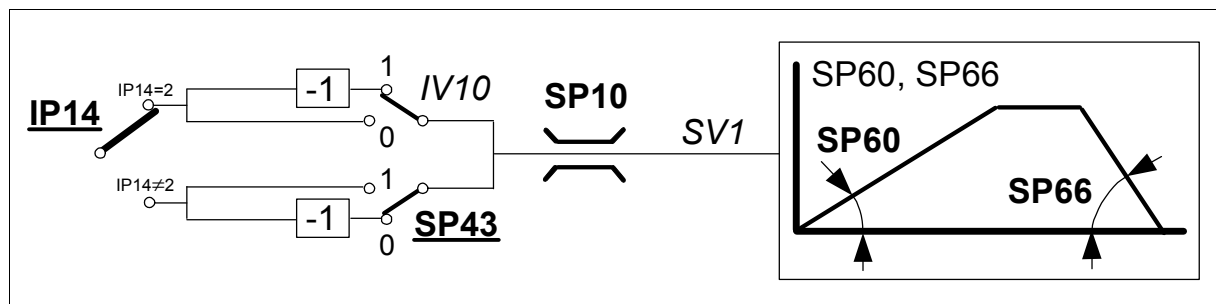

SP19 BASIC, RW**SymmetryCorrection****SP.19****Function**

Its purpose is to correct the possible difference in analog command generated to obtain exactly the same speed in both turning directions.

Valid values

- 500 ... + 500 mV.

Default value

0 mV.

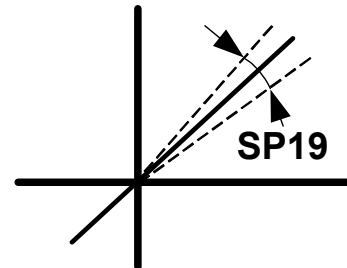
**SP20 BASIC, RW****VoltageRpmVolt****SP.20****Function**

Parameter SP20 and SP21 set the necessary ratio between the analog command and the motor speed. They correspond to the reference of the CNC concept G00 Feed.

Valid values

1.00 ... 10.00 V.

Default value

9.50 V.

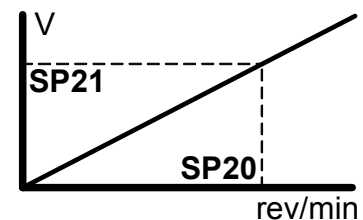
**SP21 BASIC, RW****RpmRpmVolt****SP.21****Function**

See parameter SP20.

Valid values

10 ... Motor rated speed in rev/min.

Default value

Motor rated speed in rev/min.

SP30 BASIC, RW**VelocityOffset****SP.30****Function**

Correction of the analog velocity command offset. It is applied after the analog input is treated by SP19, SP20 and SP21.

Valid values

- 2 000... + 2 000 (x 0.01 rpm)

Default value

0 rpm.

SP45 BASIC, RW

VelocityCommandSelector

SP.45

Function

This parameter is used to determine the velocity command source.

Valid values

0, 1 and 2.

Value	Function
0 (by default)	Analog. Input through pins 5 and 6 of connector X1 after being adapted by SP19, SP20 and SP21.
1	Function generator. Value of WV5 if the output of the function generator is applied to the velocity loop (WV4=1).
2	Digital. Value of SV15.

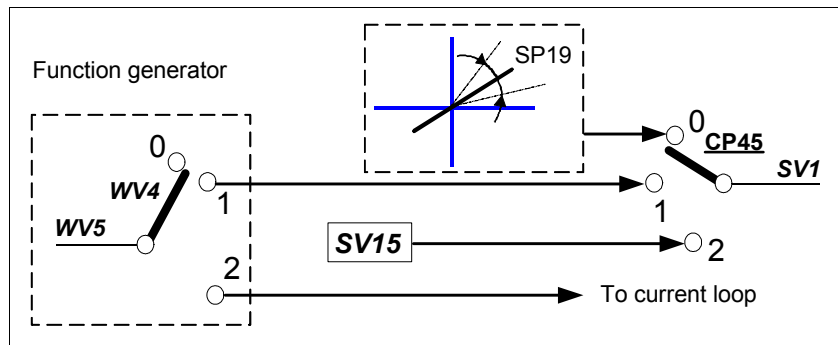

SP60 BASIC, RW

VelocityAccelerationTime

SP.60

Function

Determines the value of the acceleration ramp applied to the velocity command. Setting this parameter with a 0 value means that no ramps will be applied.

Valid values

0.0 (by default) ... 400.0 (rev/min)/ms.

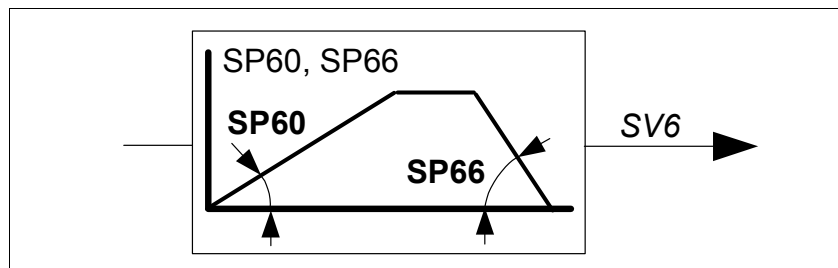

SP65 BASIC, RW

EmergencyAcceleration

SP.65

Function

In emergency stop. If the bus voltage drops or there is a power outage for the unit in the acceleration, deceleration or constant power mode, the drive will get into the dynamic braking sequence.

It stops with the emergency ramp until its speed is zero as long as the mechanical energy stored in the motor allows it. Therefore, it limits the command acceleration for stopping the motor. If anytime during the sequence, the Drive Enable is interrupted, the motor will turn by inertia. SP65=0 cancels this limiting effect.

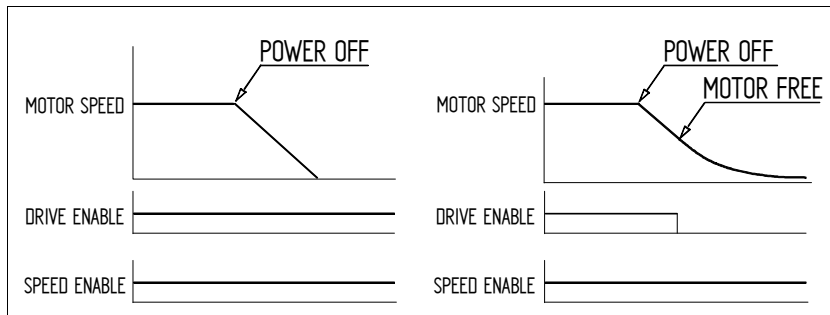

Valid values

0.0 (by default) ... 400.0 (rev/min)/ms.

SP66 BASIC, RW

VelocityDecelerationTime

SP.66

Function

Determine the value of the deceleration ramp applied to the velocity command. Setting this parameter with a 0 value means that no ramps will be applied.

Valid values

0.0 (by default) ... 400.0 (rev/min)/ms.

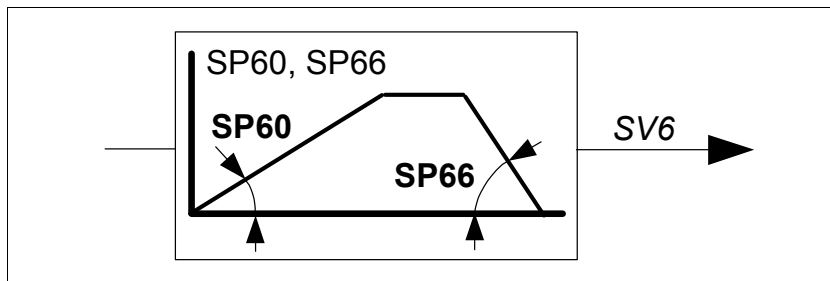

SV1 BASIC, RW

VelocityCommand

SV.01

Function

Velocity command after the SP45 selector.

Valid values

- 6 000 ... 6 000 rev/min.

SV2 BASIC, RO

VelocityFeedback

SV.02

Function

Velocity feedback.

Valid values

- 9 999 ... + 9 999 rev/min.

SV6	BASIC, RO	VelocityCommandAfterFilters	
------------	------------------	------------------------------------	---

Function Velocity command after applying limits, ramps, etc
Valid values - 9 999 ... + 9 999 rev/min.

SV7	BASIC, RO	VelocityCommandFinal	
------------	------------------	-----------------------------	---

Function Final velocity command applied to the loop.
Valid values - 9 999 ... + 9 999 rev/min.

SV15	USER, RW	DigitalVelocityCommand	
-------------	-----------------	-------------------------------	---

Function Digital velocity command.
Valid values - 6 000 ... 6 000 rev/min.

T. Torque and power

TP1	USER, RW	TorqueThresholdTx	
------------	-----------------	--------------------------	---

Function Parameter that determines the threshold for the activation of OV10 when function OutFunc2 (TorqueLimitModeCero Search) is activated.

Units Fraction of the rated value of the motor torque.

Valid values 0 ... 100 %.

Default value 5 %.

TV1	USER, RO	TorqueCommand	
------------	-----------------	----------------------	---

TV2	USER, RO	TorqueFeedback	
------------	-----------------	-----------------------	---

Function Displays the values of the command and torque feedback.

Valid values - 99.9 ... + 99.9 N·m.

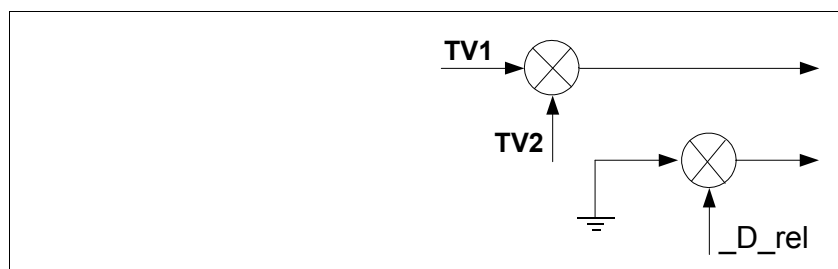

W. Internal generator

WV1	USER, RW	GeneratorShape	
------------	-----------------	-----------------------	---

Function It indicates the waveform of the internal command generator.

Valid values 0 Sinusoidal, 1 Square wave, 2 Triangular

WV2	USER, RW	GeneratorPeriod	
------------	-----------------	------------------------	---

Function It indicates the signal period of the internal command generator.

Valid values 2 ... 9 999 ms.

Default value 200 ms.

WV3	USER, RW	GeneratorAmplitude	
------------	-----------------	---------------------------	---

Function It indicates the signal amplitude of the internal command generator.

Valid values 0 ... 9 999 rev/min if it is a velocity command.

0 ... 9 999 (0.01 Arms) if it is a current command.

WV4	USER, RW	GeneratorType	
------------	-----------------	----------------------	---

Function It specifies on which magnitude the internal command is applied.

Valid values 0 Generator disconnected (by default).

1 Generator connected. Velocity command.

2 Generator connected. Current command.

WV5	USER, RO	GeneratorOutput	
------------	-----------------	------------------------	---

Function Variable that reflects the value of the signal generated by the internal function generator.

Valid values - 9 999 ... 9 999.

WV6 USER, RW

GeneratorDutyCycle

00.06

Function

For generating square signals (WV1=1), this variable specifies the ratio of the duty cycle. For example, to simulate an S6-40% cycle, WV6 = 40.

Valid values

1 ... 99 %.

Default value

50 %.

WV9 USER, RW

GeneratorOffset

00.09

Function

It allows entering an offset in the signal of the internal command generator.

Valid values

- 9 999 ... + 9 999 (rev/min). Velocity.

- 9 999 ... + 9 999 (0.01 Arms). Current.

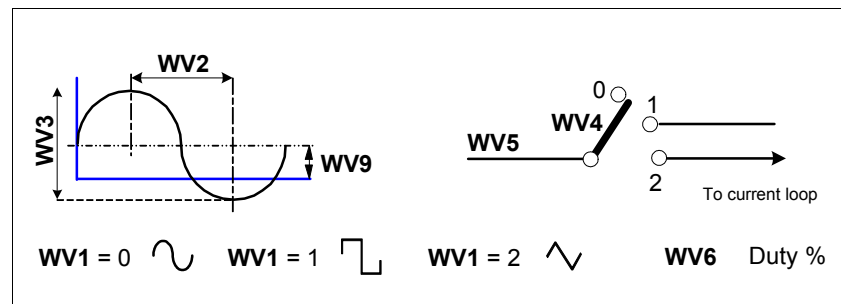

ERROR MESSAGES

E.001	Internal	
--------------	-----------------	---

Contact Fagor Automation.

E.003	At the power bus voltage	
--------------	---------------------------------	---

Cause. **ERROR.** When having torque, one of the phases of the line may have dropped.

WARNING. When starting the unit up, maybe:

- One of the three-phase lines has dropped.
- A 400 V AC unit has been supplied with 220 V AC.
- The connector of the Ballast resistor has not been installed.
- The Ballast resistor is open.

Solution. Check that the line phases and the drives are OK in the direction indicated earlier and start the system back up.

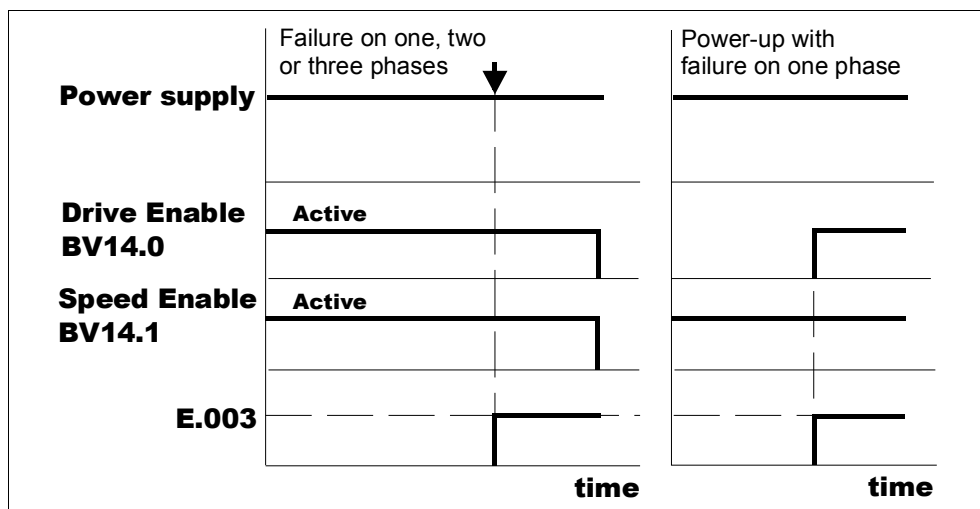

E.004	Emergency stop exceeding time limit GP3	
--------------	--	---

Cause. An attempt has been made to stop the motor by canceling **Speed Enable**. The system has tried to stop the motor at full torque, but it has not been able to stop it in the time frame set by parameter GP3 (**StoppingTimeout** = maximum time allowed for braking, before considering the error for being unable to stop it in the set time) or the parameter that determines when the motor is considered to be stopped (SP42) **Minimum velocity threshold**, is too small.

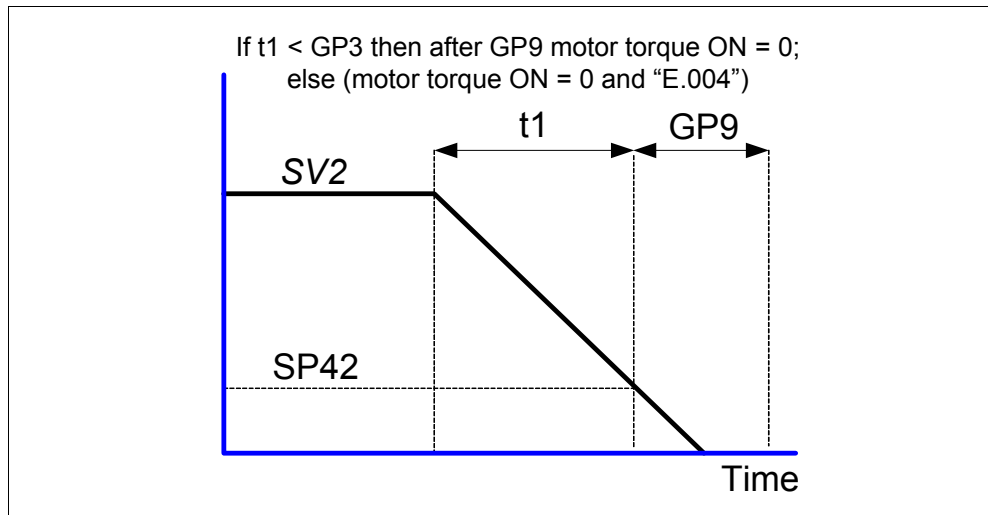

Bear in mind that zero speed (total lack of velocity) does not exist, there is always a minimum amount of speed noise due to feedback.

Solution. The load that must stop the motor is too large to stop it in the time frame set by GP3 and the value given to this parameter must be increased.

The threshold or velocity window considered zero (SP42) is too small; thus, increase the value of this parameter.

The module is performing poorly and is unable to stop the motor. The module may be defective.

E.106

Extreme temperature at the heatsink (of the IGBT's)

E. 106

Cause. The drive is carrying out a task that overheats the power devices.

Solution. Stop the system for several minutes and decrease the effort demanded from the drive.

E.108

Motor overheated

E. 108

Cause. The motor has overheated. The motor temperature measuring cables (position sensor cable) or the temperature sensor itself are defective. The application may be demanding high current peaks.

Solution. Stop the system for several minutes and decrease the effort demanded from the motor. Cool the motor.

E.200**Overspeed****E.200**

Cause. The motor speed has exceeded the value of SP10 in a 12 %.

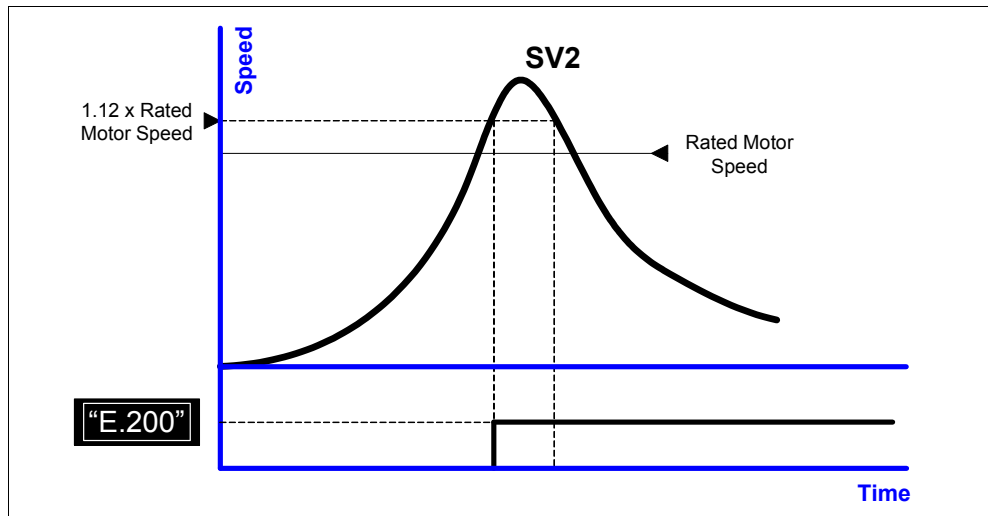

Solution. Bad cabling or poor connection of the position sensor or of the motor power.

Maybe, the velocity loop is not adjusted properly. There may be a speed overshooting in the system response. Decrease the overshooting.

E.201**Motor overload****E.201**

Cause. The duty cycle demanded from the motor is greater than it can provide causing the motor I²t protection to go off.

Solution. Change its duty cycle.

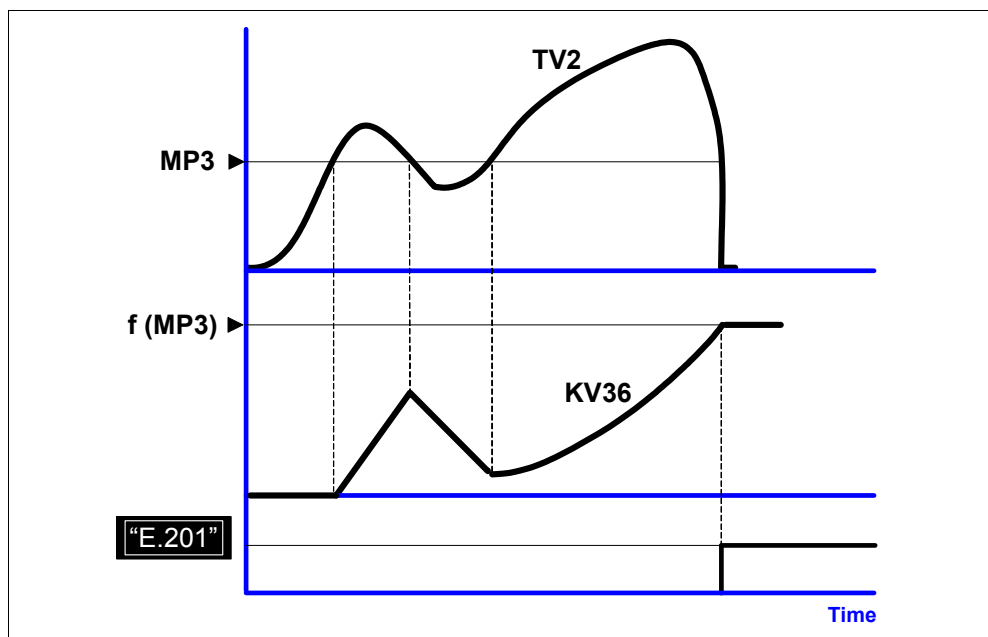

E.202**Drive overload****E.202**

Cause. The duty cycle demanded from the motor is greater than it can provide causing the drive I²t protection to go off.

Solution. Change its duty cycle.

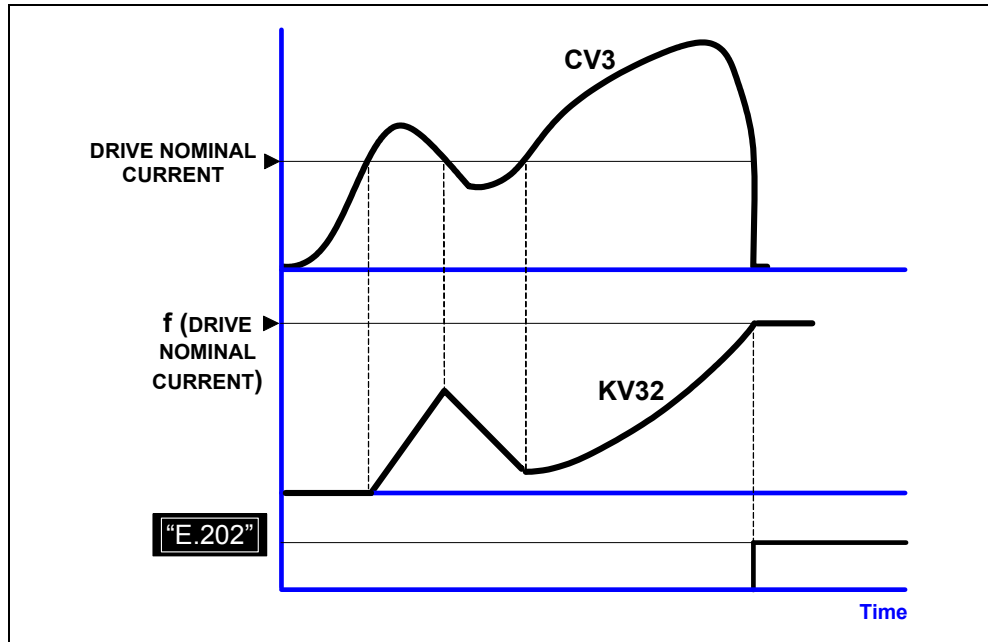
**E.214****Short-circuit****E.214**

Cause. A short-circuit has been detected at the drive module.

Solution. Perform an "error reset". If the error persists, it may be because:

- An erroneous sequence when connecting the power cables or several of them causing a short-circuit between them.
- Some wrong parameter or some failure at the drive.

If the error persists, contact Fagor Automation.

Observe that after displaying E.214, one of the codes of the following table will be displayed informing on which drive the alarm has been detected.

1L	The 1st one of the bottom	
1H	The 1st one of the top	
2L	The 2nd one of the bottom	
2H	The 2nd one of the top	
3L	The 3rd one of the bottom	
3H	The 3rd one of the top	
CR	That of the Ballast	

E.304 Power bus voltage of the drive too high

Cause. The hardware of the drive module has detected that the voltage at the power bus is too high.

Solution. Check the connection of the external Ballast resistor (if applicable) and make sure it is in good condition.
Disconnect the power supply and check the proper connection of the Ballast circuit.

E.307 Power bus voltage too low

Cause. The mains voltage is lower than the admitted minimum voltage.

Solution. Disconnect the power supply and check the proper condition of the lines.

E.314 Ballast circuit overload

Cause. Ballast resistor overload because the duty cycle forced on the circuit is too demanding.

Solution. Resize the Ballast resistor for the required duty cycle or set a less demanding duty cycle.
Smooth the duty cycle by applying acceleration ramps.

E.502 Incompatible parameters

Cause. Incompatible drive parameter setting.

E.g.: A drive to govern a motor. The motor admits a peak current of 20 A. The drive parameter that sets the current limit is set CP20=20.

If now, a 16 A peak motor is connected, the current limit will be beyond the value allowed for this new motor. The CP20 value set previously is higher than the one allowed for this new motor.

The drive notices this incompatibility and readjusts (in RAM memory) certain parameters related to speed and current and issues E.502. The QV22 variable indicates the parameters that are incompatible with each other so they can be set properly.

Observe that resetting the unit without saving the parameters causes the error to come up again. To avoid this, execute the GC1 command that permanently saves into E²PROM memory the parameters readjusted by the drive in RAM memory with their proper values.

E.506 Motor table missing

E.506

Solution. Contact Fagor Automation.

E.510 Incoherent combination of motor and feedback

E.510

Cause. The drive does not accept the motor that has been connected to it. Motor's power voltage is different from that of the drive it is connected to. For example, connecting the motor FXM34.40A.E1.000, with A winding (400 V AC) to drive MCS-20L (220 V AC).

Solution. Check that the selected motor-drive combination is coherent.

E.605 Excessive damping of the analog signals of the motor feedback

E.605

Cause. One of the sine or cosine signals of the encoder has reached a peak level lower than 150 mV.

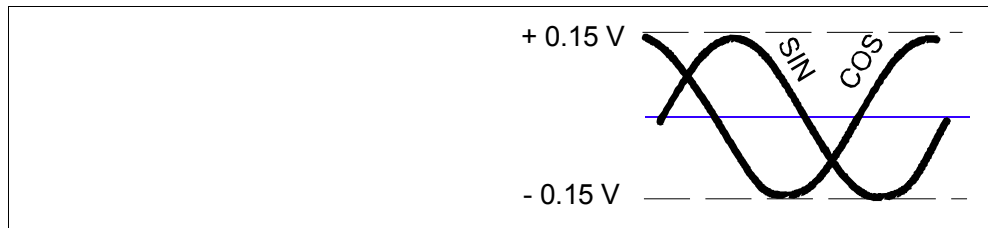

Solution. Contact Fagor Automation.

E.801 Encoder not detected

E.801

Cause. The drive has not detected the rotor sensor.

Solution. Match the selected sensor with the feedback installed and, if the error persists, contact Fagor Automation.

E.802

Defective encoder



Cause. Communication error when using a SinCos or SinCoder encoder.
Incoherent U, V, W signals when using an incremental I0 encoder.

Solution. Contact Fagor Automation.

E.803

Encoder not initialized



Solution. Contact Fagor Automation.

PARAMETERS, VARIABLES & COMMANDS. IDs

Mnem.	Name	Level	ID MODB	Ac	Min.	Max.	Def.	Units	Page
BV14	NotProgrammableIOs	FAGOR	08601	RO	0	65535	-	-	52
CP1	CurrentProportionalGain	FAGOR	00213	RW	0	999	-	-	52
CP2	CurrentIntegralTime	FAGOR	00215	RW	0	999	-	-	52
CP10	VoltageAmpVolt	USER	08823	RW	1000	9999	9500	mV	53
CP11	AmpAmpVolt	USER	08825	RW	100	5000	5000	cA	53
CP20	CurrentLimit	BASIC	08807	RW	0	5000	0	cA	53
CP30	CurrentCommandFilter1Type	FAGOR	08809	RW	0	1	0	-	53
CP31	CurrentCommandFilter1Frequency	FAGOR	08817	RW	0	4000	0	Hz	54
CP32	CurrentCommandFilter1Damping	FAGOR	08819	RW	0	1000	0	Hz	54
CP45	CurrentCommandSelector	USER	08821	RW	0	3	0	-	54
CV1	Current1Feedback	USER	08811	RO	- 5000	5000	-	cA	55
CV2	Current2Feedback	USER	08813	RO	- 5000	5000	-	cA	55
CV3	CurrentFeedback	USER	08815	RO	- 5000	5000	-	cA	55
CV10	Current1Offset	FAGOR	08803	RO	- 2000	2000	-	mA	55
CV11	Current2Offset	FAGOR	08805	RO	- 2000	2000	-	mA	56
CV15	DigitalCurrentCommand	USER	08827	RW	- 5000	5000	0	cA	56
DC1	ResetClass1Diagnostics	USER	00199	RW	0	15	0	-	57
DC2	ClearHistoricOfErrorsCommand	USER	08997	RW	0	15	0	-	58
DV17	HistoricOfErrors	USER	09012	RO	-	-	-	-	56
DV31	DriverStatusWord	FAGOR	00271	RO	0	65535	-	-	57
DV32	MasterControlWord	FAGOR	00269	RW	0	65535	0	-	57
EP1	EncoderSimulatorPulsesPerTurn	BASIC	09193	RW	0	4096	-	-	58
EP3	EncoderSimulatorDirection	BASIC	09197	RW	0	1	0	-	58
EP4	EncoderSimulatorHighFreqEnable	BASIC	09201	RW	0	1	0	pulses	58
GC1	BackupWorkingMemoryCommand	BASIC	00529	RW	0	15	0	-	61
GC3	AutophasingCommand	FAGOR	09653	RW	0	15	0	-	61
GC10	LoadDefaultsCommand	BASIC	00525	RW	0	15	0	-	61
GP3	StoppingTimeout	BASIC	09597	RW	0	9999	500	ms	59
GP5	ParameterVersion	BASIC	09601	RO	-	-	-	-	59
GP9	DriveOffDelayTime	BASIC	00415	RW	0	9999	50	ms	59
GP11	IOFunctionsTime	USER	09645	RW	0	9999	2000	ms	59
GP15	AutomaticInitialization	FAGOR	09643	RW	0	1	1	-	59
GP16	MonoPhaseSelector	BASIC	09647	RW	0	1	0	-	60
GV2	ManufacturerVersion	BASIC	00060	RO	-	-	-	-	60
GV5	CodeChecksum	BASIC	09605	RO	-	-	-	-	60
GV7	Password	BASIC	00535	RW	0	9999	0	-	60
GV9	DriveType	BASIC	00280	RO	-	-	-	-	60
GV11	SoftReset	BASIC	09609	RW	0	16	0	-	60
GV16	MotorTableVersion	BASIC	09625	RO	-	-	-	-	61
GV75	ErrorList	FAGOR	00750	RO	-	-	-	-	61
HV5	PLDVersion	BASIC	08783	RO	-	-	-	-	62
IP6	DigitalInputPolarity	USER	10013	RW	0	1	0	-	62
IP14	DigitalInputFunctionSelector	USER	10015	RW	0	4	4	-	62
IP17	AnalogFunctionSelector	USER	10017	RW	0	2	0	-	63
IV1	AnalogInput1	BASIC	10003	RO	- 12000	12000	-	mV	63
IV2	AnalogInput2	USER	10005	RO	- 1200	1200	-	cV	63
IV3	CurrentCommandAfterScaling	USER	10019	RO	- 9999	9999	-	cA	63
IV10	DigitalInputs	USER	10007	RO	0	1	-	-	63
KP3	ExtBallastPower	USER	10421	RW	200	2000	200	W	64
KP4	ExtBallastEnergyPulse	USER	10425	RW	200	2000	200	J	64
KV6	MotorTemperature	BASIC	00767	RO	- 20	200	-	° C	64
KV10	CoolingTemperature	USER	10397	RO	- 20	200	-	° C	64
KV32	I2tDrive	USER	10410	RO	0	100	-	%	64
KV36	I2tMotor	USER	10415	RO	0	100	-	%	64
KV40	I2tCrowbar	USER	10423	RO	0	100	-	%	65
KV41	BallastSelect	USER	10427	RW	0	1	1	-	65
MP1	MotorType	BASIC	00282	RW	-	-	-	-	65
MP2	MotorTorqueConstant	FAGOR	10593	RW	0	100	-	dNm/A	65

Mnem.	Name	Level	ID MODB	Ac	Min.	Max.	Def.	Units	Page
MP3	MotorContinuousStallCurrent	FAGOR	00223	RW	0	5000	-	cA	66
OP1	DA1IDN	USER	10993	RW	0	13	4	-	66
OP2	DA2IDN	USER	10995	RW	0	13	7	-	66
OP3	DA1ValuePer10Volt	USER	10997	RW	0	9999	4000	-	67
OP4	DA2ValuePer10Volt	USER	10999	RW	0	9999	3000	-	67
OP6	DigitalOutputPolarity	USER	11025	RW	0	1	0	-	67
OP14	DigitalOutputFunctionSelector	USER	11021	RW	0	7	0	-	67
OP15	DigitalOutputWarningSelector	USER	11023	RW	0	2	0	-	68
OV10	DigitalOutputs	USER	11013	RO	0	1	0	-	68
QP14	ProtocolTypeSelector	USER	12213	RW	0	7	2	-	68
QP16	SerialSettings	USER	12217	RW	0	65535	1540	-	69
QV22	IDNListOffInvalidOperationData	FAGOR	00044	RO	-	-	-	-	70
QV96	SlaveArrangement	USER	00193	RW	0	127	1	-	70
RC1	EncoderParameterStoreCommand	FAGOR	11219	RW	0	15	0	-	71
RP1	FeedbackSineGain	FAGOR	11193	RW	0	8192	4096	-	70
RP2	FeedbackCosineGain	FAGOR	11195	RW	0	8192	4096	-	70
RP3	FeedbackSineOffset	FAGOR	11197	RW	- 2000	2000	0	-	70
RP4	FeedbackCosineOffset	FAGOR	11199	RW	- 2000	2000	0	-	70
RP20	StegmanABLevelSense	USER	11267	RW	30	100	100	%	71
RV1	FeedbackSine	USER	11205	RO	- 512	511	-	-	71
RV2	FeedbackCosine	USER	11207	RO	- 512	511	-	-	71
RV3	FeedbackRhoCorrection	FAGOR	11209	RO	0	65535	-	-	71
SP1	VelocityProportionalGain	BASIC	00201	RW	0	9999	-	dmArms/rpm	72
SP2	VelocityIntegralTime	BASIC	00203	RW	0	9999	-	dms	72
SP3	VelocityDerivativeGain	BASIC	00205	RW	0	9999	0	-	72
SP10	VelocityLimit	BASIC	00183	RW	0	9999	1000	rev/min	72
SP19	SymmetryCorrection	BASIC	11431	RW	- 500	500	0	mV	73
SP20	VoltageRpmVolt	BASIC	11433	RW	1000	9999	9500	mV	73
SP21	RpmRpmVolt	BASIC	11435	RW	10	9999	4000	rev/min	73
SP30	VelocityOffset	BASIC	11399	RW	- 2000	2000	0	crpm	73
SP40	VelocityThresholdNx	USER	00251	RW	0	9999	1000	rev/min	74
SP41	VelocityWindow	USER	00315	RW	0	9999	20	rev/min	74
SP42	StandStillWindow	USER	00249	RW	0	9999	20	rev/min	74
SP43	VelocityPolarityParameters	BASIC	00087	RW	0	1	0	-	74
SP45	VelocityCommandSelector	BASIC	11427	RW	0	2	0	-	75
SP60	AccelerationLimit	BASIC	00277	RW	0	4000	0	drpm/ms	75
SP65	EmergencyAcceleration	BASIC	11411	RW	0	4000	0	drpm/ms	75
SP66	VelocityDecelerationTime	BASIC	11429	RW	0	4000	0	drpm/ms	76
SV1	VelocityCommand	BASIC	00072	RW	- 6E7	6E7	0	dmrpm	76
SV2	VelocityFeedback	BASIC	00080	RO	- 6E7	6E7	-	dmrpm	76
SV6	VelocityCommandAfterFilters	BASIC	11436	RO	- 6E7	6E7	-	dmrpm	77
SV7	VelocityCommandFinal	BASIC	11416	RO	- 6E7	6E7	-	dmrpm	77
SV15	DigitalVelocityCommand	USER	11438	RW	- 6E7	6E7	0	dmrpm	77
TP1	TorqueThresholdTx	USER	00253	RW	0	100	5	%	77
TV1	TorqueCommand	USER	00161	RO	- 9999	9999	0	dN·m	77
TV2	TorqueFeedback	USER	00169	RO	- 9999	9999	-	dN·m	77
WV1	GeneratorShape	USER	11793	RW	0	2	1	-	78
WV2	GeneratorPeriod	USER	11795	RW	2	9999	200	ms	78
WV3	GeneratorAmplitude	USER	11797	RW	0	9999	0	-	78
WV4	GeneratorType	USER	11799	RW	0	2	0	-	78
WV5	GeneratorOutput	USER	11801	RO	- 9999	9999	0	-	78
WV6	GeneratorDutyCycle	USER	11803	RW	1	99	50	%	79
WV9	GeneratorOffset	USER	11809	RW	- 9999	9999	0	-	79

Oficinas subsidiarias de FAGOR.

SPAIN

Sede Central: FAGOR AUTOMATION S.COOP.

Bº San Andrés 19, Apdo. 144
E-20500 ARRASATE-MONDRAGON
www.fagorautomation.com
E-mail: info@fagorautomation.es
Tel: 34-943-719200 / 34-943-039800
Fax: 34-943-791712
34-943-771118 (Service Dept.)

Usurbil:

FAGOR AUTOMATION S.COOP.

Planta de Usurbil
San Esteban s/n Txoko-Alde
E-20170 USURBIL
Tel: 34-943-000690
Fax: 34-943-360527
E-mail: usurbil@fagorautomation.es

Eskoriatza:

FAGOR AUTOMATION S.COOP.

Planta de Eskoriatza
Torrebaso Pasealekua, 4, Apdo. 50
E-20540 ESKORIATZA
Tel: 34-943-719200
Fax: 34-943-039783

Barcelona:

FAGOR AUTOMATION, Catalunya
Parc Tecnològic del Vallès,
Tecnoparc II
Edificio I Módulo Ab
C/Argenters, 5
08290 Cerdanyola del Vallès
Tel.: 34-93-4744375
Fax: 34-93-4744327
E-mail: del.catalunya@barna.fagorautomation.es

FRANCE

FAGOR AUTOMATION FRANCE Sàrl
Parc Technologique de La Pardieu
16 Rue Patrick Depailler
63000 CLERMONT FERRAND
Tel.: 33-473277916
Fax: 33-473150289
fagorautomation@wanadoo.fr

GERMANY

FAGOR AUTOMATION GmbH
Postfach 604 D-73006 GÖPPINGEN
Nördliche Ringstrasse, 100
Tel.: 49-7161 15685-0
Fax: 49-7161 1568579
E-mail: automation@fagor.de

ITALY

FAGOR ITALIA S.R.L.
Pal. CD3 P.T. - Via Roma, 108
20060 CASSINA DE PECCHI (MI)
Tel.: 39-0295301290
Fax: 39-0295301298
E-mail: italy@fagorautomation.it

UNITED KINGDOM

FAGOR AUTOMATION UK Ltd.
2 A Brunel Close
Drayton Field Industrial Estate
Daventry Northamptonshire
NN11 8RB
Tel: 44-1327 300067
Fax: 44-1327 300880
E-mail: info@fagorautomation.co.uk

PORTUGAL

FAGOR AUTOMATION LTDA.
Sucursal Portuguesa
Rua Gonçalves Zarco nº 1129-B-2º
Salas 210/212
4450 LEÇA DA PALMEIRA
Tel: 351 22 996 88 65
Fax: 351 22 996 07 19
E-mail: fagorautomation@fagorautomation.pt

USA

Chicago:

FAGOR AUTOMATION CORP.
2250 Estes Avenue
ELK GROVE VILLAGE, IL 60007
Tel: 1-847-9811500
1-847-9811595 (Service)
Fax: 1-847-9811311
E-mail: fagorusa@fagor-automation.com

California:

FAGOR AUTOMATION West Coast
3176 Pullman Ave., Unit 110
COSTA MESA, CA 92626
Tel: 1-714-9579885
Fax: 1-714-9579891
E-mail: caservice@fagor-automation.com

New Jersey:

FAGOR AUTOMATION East Coast
Tel: 1-973-7733525
Fax: 1-973-7733526
E-mail: wnelson@fagor-automation.com

South East:

FAGOR AUTOMATION SOUTH EAST
4234 Amber Ridge Ln- VALRICO, FL 33594
Tel: 813 654 4599
E-mail: jkas@fagor-automation.com

Ohio:

FAGOR AUTOMATION OHIO BRANCH
Westerville OH 43081
Tel: 1 614-855-5720
Fax: 1 614-855-5928
E-mail: tdrane@fagor-automation.com

CANADA

Ontario:

FAGOR AUTOMATION ONTARIO
Unit 3, 6380 Tomken Road
MISSISSAUGA L5T 1Y4
Tel: 1-905-6707448
Fax: 1-905-6707449
E-mail: sales@fagorautomation.on.ca

Montreal:

FAGOR AUTOMATION QUEBEC
Tel.: 1-450-2270588
Fax: 1-450-2276132
E-mail: montreal@fagorautomation.on.ca

Windsor:

FAGOR AUTOMATION WINDSOR
Tel.: 1-519 944-5674
Fax: 1-519 944-2369

BRAZIL

FAGOR AUTOMATION DO BRASIL
COM.IMP. E EXPORTAÇÃO LTDA.
Rua Homero Baz do Amaral, 331
CEP 04774-030 SAO PAULO-SP
Tel.: 55-11-56940822
Fax: 55-11-56816271
E-mail: brazil@fagorautomation.com.br

CHINA

Beijing:

BEIJIN FAGOR AUTOMATION EQUIPMENT
Co.,LTD.
C-1 Yandong Building,
No.2 Wanhong Xijie, Xibajianfang
Chaoyang District
BEIJING, Zip Code: 100015
Tel: 86-10-84505858
Fax: 86-10-84505860
E-mail: info@fagorautomation.com.cn

Nanjing:

FAGOR AUTOMATION EQUIPMENT LTD.
NANJING OFFICE
Room 803, Holiday Inn (Nanjing)
45 Zhongshan Beilu,
210008 NANJING, P.R. CHINA
Tel: 86-25-83328259
Fax: 86-25-83328260
E-mail: fagor_nj@fagorautomation.com.cn

Guangzhou:

Beijin FAGOR AUTOMATION Equipment Ltd.
Guangzhou Office
Room 915 Lihao Plaza
No. 18 Jichanglu Baiyun District
510405 GUANGZHOU, P.R. CHINA.
Tel: 86-20-86553124
Fax: 86-20-86553125
E-mail: fagor_gz@fagorautomation.com.cn

Shanghai:

Beijing FAGOR AUTOMATION equipment
Ltd. SHANGHAI BRANCH
Room No.547 Tianmu Xilu
20070 SHANGHAI, P.R. CHINA.
Tel: 86-21-63539007/63538919
Fax: 86-21-63538840
E-mail: fagor_sh@fagorautomation.com.cn

Chengdu:

Beijing FAGOR AUTOMATION equipment
Ltd. Chengdu Office
Room 912, No. 16 Dayelu
610100 CHENGDU, P.R. CHINA.
Tel: 86-28-66132081
Fax: 86-28-66132082
E-mail: fagor_cd@fagorautomation.com.cn

HONG KONG

FAGOR AUTOMATION (ASIA) LTD.
Room 628, Tower II, Grand Central Plaza
138 Shatin Rural Committee Road
Shatin, HONG KONG
Tel: 852-23891663
Fax: 852-23895086
E-mail: fagorhk@fagorautomation.com.hk

KOREA, Republic of

FAGOR AUTOMATION KOREA, LTD.
Room No. 707 Byucksan Digital Valley 2nd
481-10 Gasan-dong, Geumcheon-gu
Seoul 153-803, Korea
Tel: 82 2 2113 0341
Fax: 82 2 2113 0343
E-mail: korea@fagorautomation.com.kr

TAIWAN, R.C.O.

FAGOR AUTOMATION TAIWAN CO., LTD.
Nº 24 Ta-Kuang St. Nan-Tun Dist. 408
Taichung, TAIWAN R.O.C.
Tel: 886-4-2 3271282
Fax: 886-4-2 3271283

SINGAPORE

FAGOR AUTOMATION (S) PTE.LTD.
240 MacPherson Road
06-05 Pines Industrial Building
SINGAPORE 348574
Tel: 65-68417345 / 68417346
Fax: 65-86417348
E-mail: singapore@fagorautomation.com.sg

MALAYSIA

FAGOR AUTOMATION (M) SDN.BHD.
(638038-H)
No.39, Jalan Utama 1/7
Taman Perindustrian Puchong Utama
47100 Puchong, Selangor Darul Ehsan
Tel: +60 3 8062 2858
Fax: +60 3 8062 3858
E-mail: malaysia@fagorautomation.com.sg

VELOCITY CONTROL BLOCK DIAGRAM

General parameters	
GV2	Software version
GV7	Password
GC10	Default parameters
GV11	Soft Reset
GC1	Store parameters
GV9	Drive type
GV5	Code Checksum
GC3	Autophasing command

Display	Drive Status
L. buS	Waiting P. Supply
(.)	Drive Ready
(rdy1)	Motor running
(rdy0)	Motor running speed = 0
(rdy-)	Drive enable (ON) and no pulses

ERROR	DESCRIPTION
E.001	Watch Dog
E.003	Power supply fault / warning
E.004	Stop time > GP3
E.106	Drive overtemp
E.108	Motor overtemp
E.200	Overspeed
E.201	I2t Motor
E.202	I2t Drive
E.214	Short-circuit
E.304	Bus overvoltage
E.307	Bus low voltage
E.314	I2t Ballast
E.502	Incompatible parameters
E.506	Motor table missing
E.510	Incoherent combination of motor & feedback
E.605	Feedback signals excessively damped
E.801	Encoder not detected
E.802	Defective encoder
E.803	Encoder not initialized

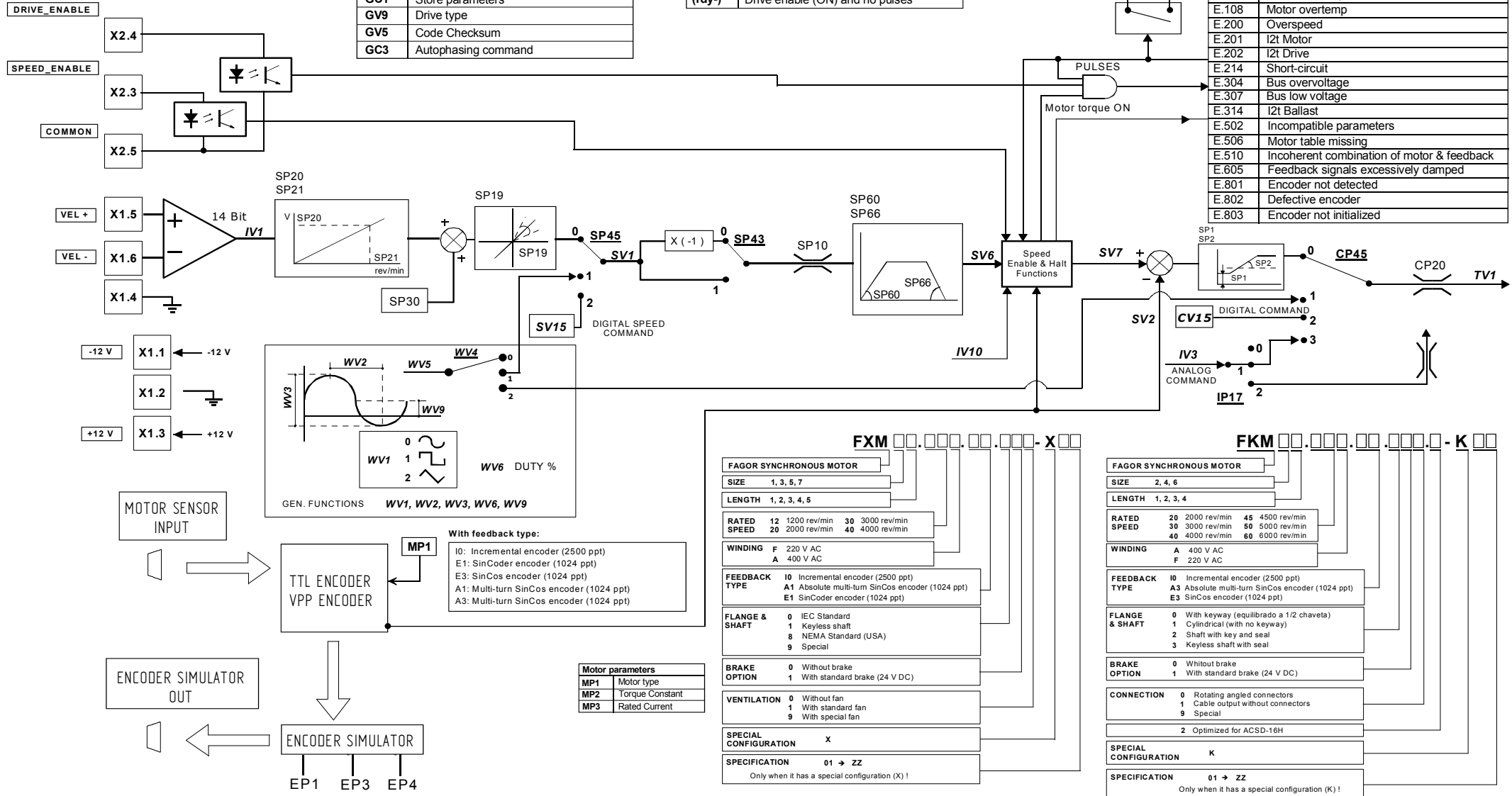

Motor parameters	
MP1	Motor type
MP2	Torque Constant
MP3	Rated Current

FXM	
FAGOR SYNCHRONOUS MOTOR	
SIZE	1, 3, 5, 7
LENGTH	1, 2, 3, 4, 5
RATED SPEED	12 1200 rev/min 30 3000 rev/min 40 4000 rev/min
WINDING	F 220 V AC A 400 V AC
FEEDBACK TYPE	I0 Incremental encoder (2500 ppt) A1 Absolute multi-turn SinCos encoder (1024 ppt) E1 SinCoder encoder (1024 ppt)
FLANGE & SHAFT	0 IEC Standard 1 Keyless shaft 8 NEMA Standard (USA) 9 Special
BRAKE OPTION	0 Without brake 1 With standard brake (24 V DC)
VENTILATION	0 Without fan 1 With standard fan 9 With special fan
SPECIAL CONFIGURATION	X
SPECIFICATION	01 → ZZ Only when it has a special configuration (X) !

FKM	
FAGOR SYNCHRONOUS MOTOR	
SIZE	2, 4, 6
LENGTH	1, 2, 3, 4
RATED SPEED	20 2000 rev/min 45 4500 rev/min 50 5000 rev/min 60 6000 rev/min
WINDING	A 400 V AC F 220 V AC
FEEDBACK TYPE	I0 Incremental encoder (2500 ppt) A3 Absolute multi-turn SinCos encoder (1024 ppt) E3 SinCoder encoder (1024 ppt)
FLANGE & SHAFT	0 With keyway (equilibrado a 1/2 chaveta) 1 Cylindrical (with no keyway) 2 Shaft with key and seal 3 Keyless shaft with seal
BRAKE OPTION	0 Whitout brake 1 With standard brake (24 V DC)
CONNECTION	0 Rotating angled connectors 1 Cable output without connectors 9 Special 2 Optimized for ACSD-16H
SPECIAL CONFIGURATION	K
SPECIFICATION	01 → ZZ Only when it has a special configuration (K) !

Note: Any motor with F type winding (220 VAC) can have an incremental TTL encoder (ref. I0). The rest of encoders (ref. E1 and A1) will only available on motors with A type winding (400 VAC).
 Note: Any motor with F type winding (220 VAC) can have an incremental TTL encoder (ref. I0). The rest of encoders (ref. E3 and A3) will only available on motors with A type winding (400 VAC).

I/O FUNCTIONS

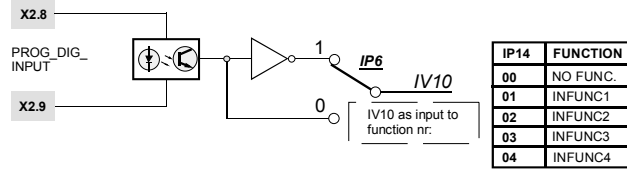

FUNCTION	OP14
NO FUNC.	00
OUTFUNC1	01
OUTFUNC2	02
OUTFUNC3	03
OUTFUNC4	04
OUTFUNC5	05
OUTFUNC6	06
OUTFUNC7	07

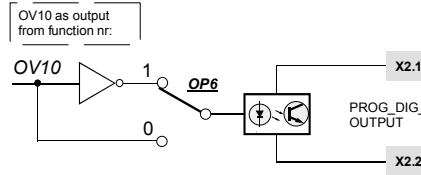

IP14 01 REMOTE P. / P.I. CONTROL

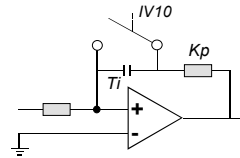

IP14 02 SERVOMOTOR ROTATION DIRECTION

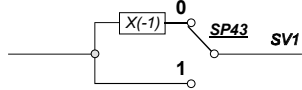

IP14 03 HALT

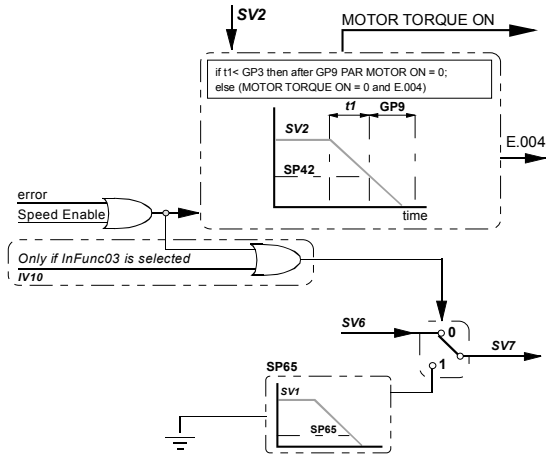

IP14 04 ERROR RESET

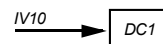

OP14 01 MOTOR BRAKE CONTROL

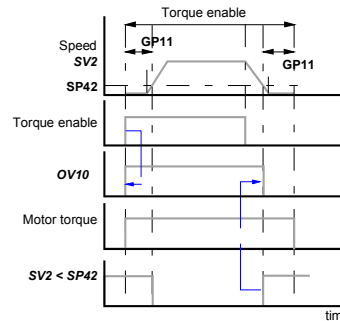

OP14 02 TORQUE LIMIT

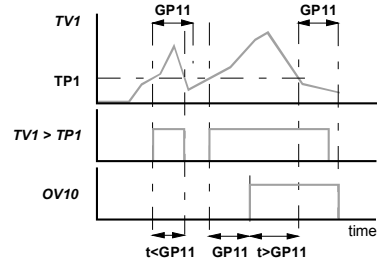

OP14 03 MOTOR SPEED > SP40

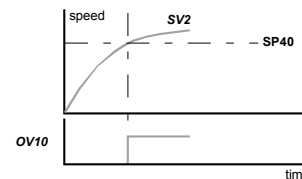

OP14 04 TARGET SPEED

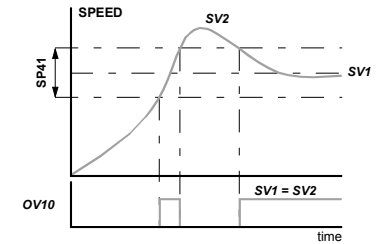

OP14 05 TARGET SPEED < 0 REV/MIN

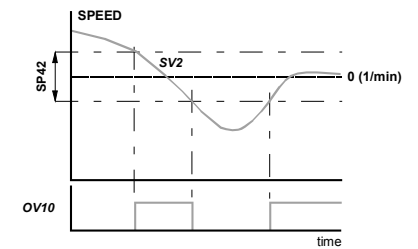

OP14 06 SECOND DR OK

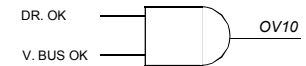

OP14 07 WARNINGS

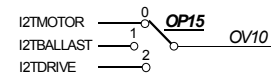

ANALOG FUNCTIONS

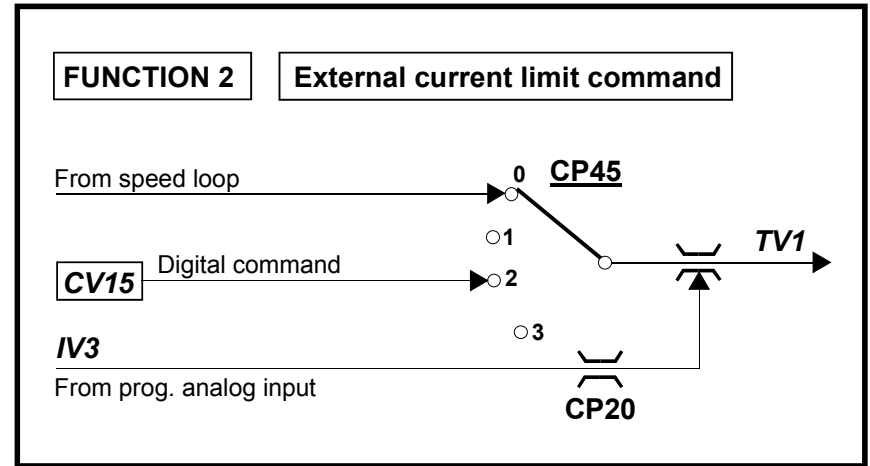
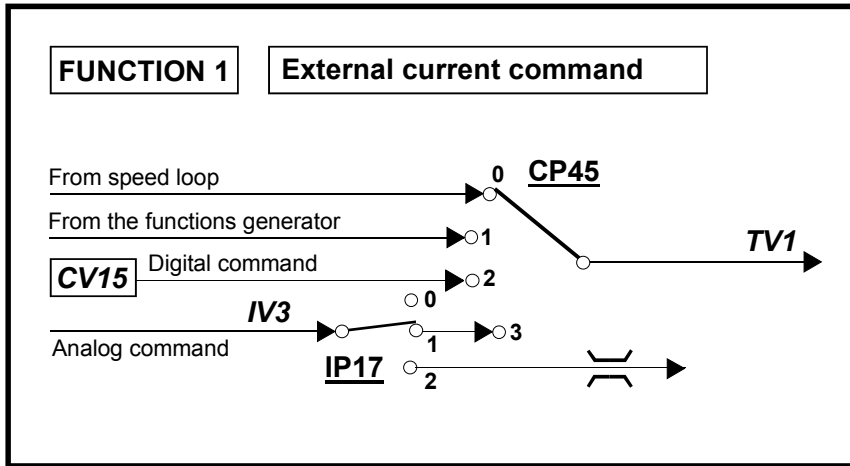
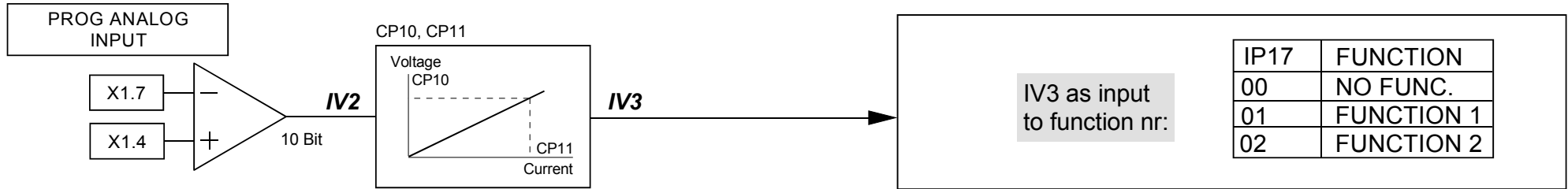

OP1	VARIABLE	OP2	VARIABLE	UNITS
00	SV15	00	SV15	1/min
01	SV1	01	SV1	1/min
02	SV6	02	SV6	1/min
03	SV7	03	SV7	1/min
04	SV2	04	SV2	1/min
05	TV1	05	TV1	10 ⁻¹ ·Nm
06	TV2	06	TV2	10 ⁻¹ ·Nm
07	CV3	07	CV3	10 ⁻² ·A
08	WV5	08	WV5	-
09	IV1	09	IV1	mV
10	IV2	10	IV2	mV
11	RV1	11	RV1	bits
12	RV2	12	RV2	bits

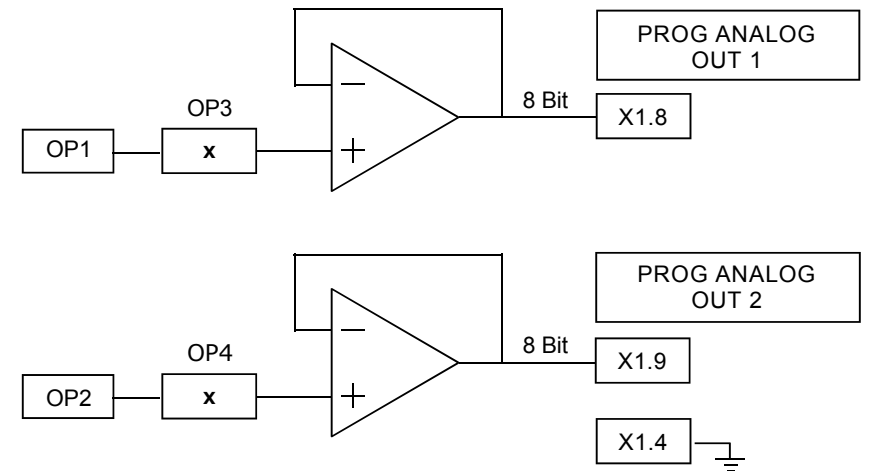

ERROR FUNCTIONS

Function «E.003»

Power supply fault

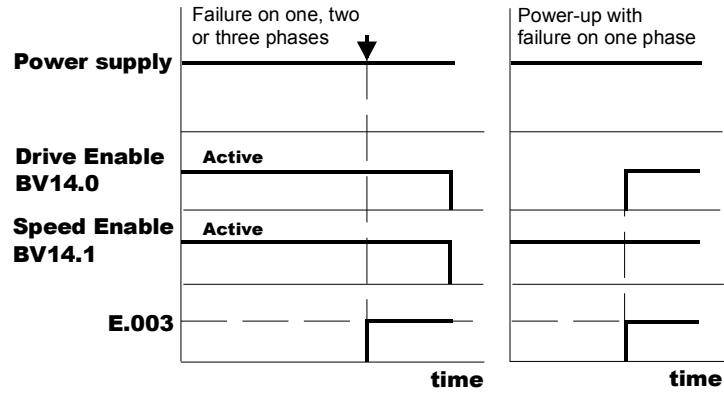

Function «E.106»

Drive overtemperature

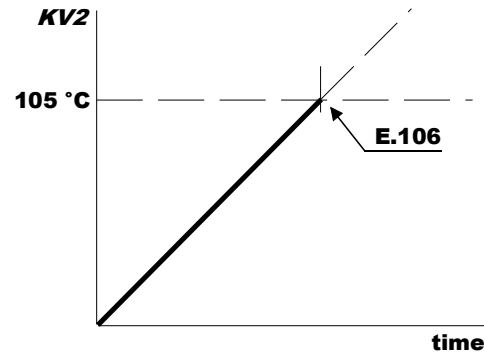

Function «E.200»

Overspeed

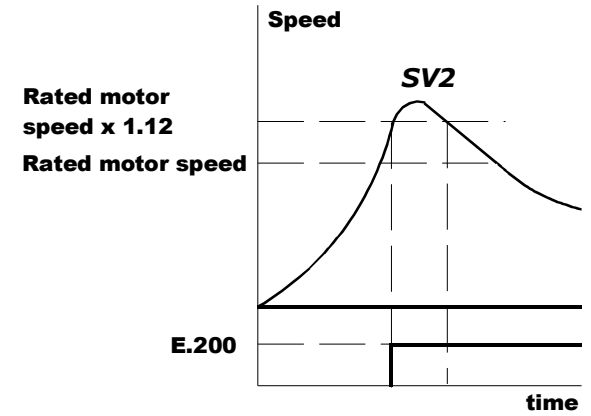

Function «E.201»

Motor overload

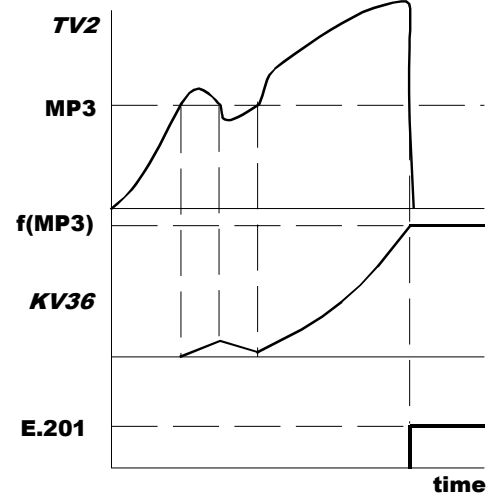

Function «E.202»

Drive overload

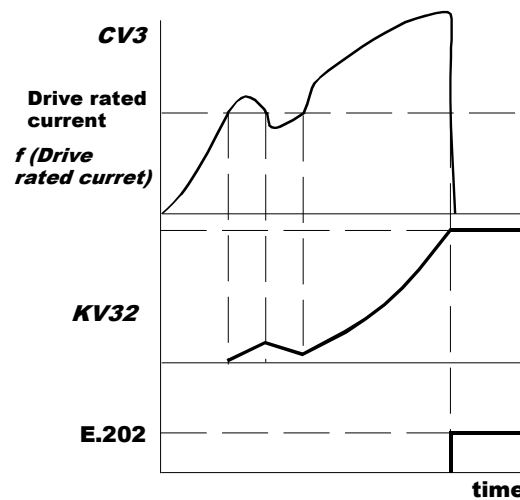

Function «E.314»

Ballast overload

KV41	1	Internal Ballast resistor
KV41	0	External Ballast resistor

